



# Cutoutil

Metal Carbide Inserts, Turning Tools, Indexable Milling, Carbide Drill

www.cutoutil.com

## 复合式95°偏头外圆端面车刀



CNMG, CNMA, CNMM

### MCLNR/L 外圆, 端面加工



型号	刀体几何尺寸				适用刀片	产品货号		刀垫	锁紧销	压板	双头螺丝	板手
	A	B	F	C		右刀	左刀					
MCLNR/L2020K12	20	20	25	125	CN..1204	2300-0010	2300-1010	C1203B	NL-0617	CL-12	XNS-0829	S2.5 S4
MCLNR/L2520M12	20	25	25	150	CN..1204	2300-0011	2300-1011					
MCLNR/L2525M12	25	25	32	150	CN..1204	2300-0012	2300-1012	C1604B	NL-0822	CL-12	XNS-0829	S3 S4
MCLNR/L2525M16	25	25	32	150	CN..1606	2300-0016	2300-1016					
MCLNR/L3225P16	25	32	32	170	CN..1606	2300-0018	2300-1018	C1904B	NL-0823	CL-30	XNS-0829	S4
MCLNR/L3232P16	32	32	40	170	CN..1606	2300-0020	2300-1020					
MCLNR/L3232P19	32	32	40	170	CN..1906	2300-0021	2300-1021	C1904B	NL-0823	CL-30	XNS-0829	S4
MCLNR/L4040R19	40	40	50	200	CN..1906	2300-0022	2300-1022					

## 英制

MODEL	DIMENSIONS				FOR INSERT	ITEM NO.		SHIM	SHIM PIN	CLAMP	CLAMP SCREW	HEXKEY
	A	B	F	C		RIGHT	LEFT					
MCLNR/L12-4B	0.75	0.75	1.00	4.5	CN..432	2300-5008	2300-6008	C1203B	NL-0617	CL-12	XNS-0829	S2.5 S4
MCLNR/L12-4C	0.75	0.75	1.00	5.0	CN..432	2300-5010	2300-6010					
MCLNR/L16-4C	1.00	1.00	1.25	5.0	CN..432	2300-5014	2300-6014	C1604B	NL-0822	CL-12	XNS-0829	S3 S4
MCLNR/L16-4D	1.00	1.00	1.25	6.0	CN..432	2300-5016	2300-6016					
MCLNR/L20-4E	1.25	1.25	1.50	7.0	CN..432	2300-5026	2300-6026	C1904B	NL-0823	CL-30	XNS-0829	S4
MCLNR/L24-4F	1.50	1.50	2.00	8.0	CN..432	2300-5032	2300-6032					
MCLNR/L16-5C	1.00	1.00	1.25	5.0	CN..543	2300-5018	2300-6018	C1904B	NL-0823	CL-30	XNS-0829	S4
MCLMR/L16-5D	1.00	1.00	1.25	6.0	CN..543	2300-5020	2300-6020					
MCLNR/L20-5E	1.25	1.25	1.50	7.0	CN..543	2300-5028	2300-6028	C1904B	NL-0823	CL-30	XNS-0829	S4
MCLNR/L20-6E	1.25	1.25	1.50	7.0	CN..643	2300-5030	2300-6030					



# Cutoutil

Metal Carbide Inserts, Turning Tools, Indexable Milling, Carbide Drill

www.cutoutil.com

## 复合式75°偏头外圆车刀



CNMG, CNMA, CNMM

## MCRNR/L 外圆加工

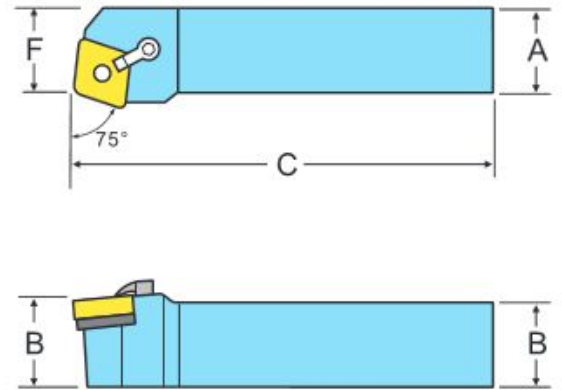

型号	刀体几何尺寸				适用刀片	产品货号		刀垫	锁紧销	压板	双头螺丝	板手
	A	B	F	C		右刀	左刀					
MCRNR/L2020K12	20	20	22	125	CN..1204	2301-0024	2301-1024	C1203B	NL-0617			S2.5 S4
MCRNR/L2525M12	25	25	27	150	CN..1204	2301-0026	2301-1026					
MCRNR/L2525M16	25	25	27	150	CN..1606	2301-0030	2301-1030			CL-12		
MCRNR/L3225P16	25	32	27	170	CN..1606	2301-0032	2301-1032	C1604B	NL-0822		XNS-0829	S3 S4
MCRNR/L3232P16	32	32	35	170	CN..1606	2301-0034	2301-1034					
MCRNR/L4040R19	40	40	43	200	CN..1906	2301-0036	2301-1036	C1904B	NL-0823	CL-30		S4

## 英制

MODEL	DIMENSIONS				FOR INSERT	ITEM NO.		SHIM	SHIM PIN	CLAMP	CLAMP SCREW	HEXKEY
	A	B	F	C		RIGHT	LEFT					
MCRNR/L12-4C	0.75	0.75	0.875	5.0	CN..432	2301-5034	2301-6034					
MCRNR/L16-4D	1.00	1.00	1.125	6.0	CN..432	2301-5038	2301-6038	C1203B	NL-0617	CL-12	XNS-0829	S2.5 S4
MCRNR/L20-4E	1.25	1.25	1.313	7.0	CN..432	2301-5042	2301-6042					

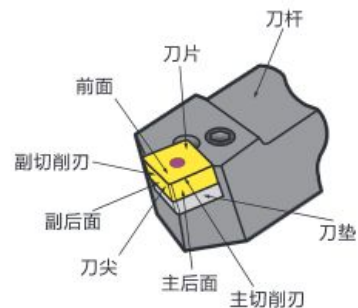
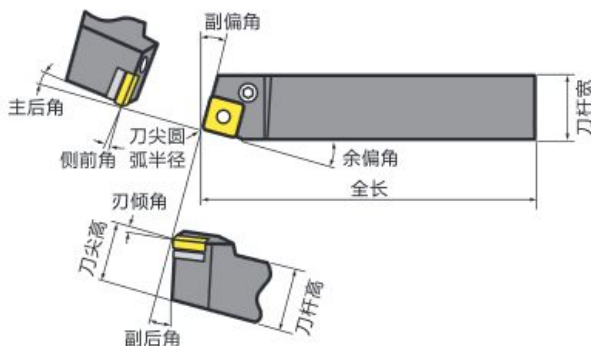





# Cutoutil

Metal Carbide Inserts, Turning Tools, Indexable Milling, Carbide Drill

www.cutoutil.com

## 复合式93°偏头外圆仿形车刀



DNMG, DNMA

## MDJNR/L 外圆，仿形加工

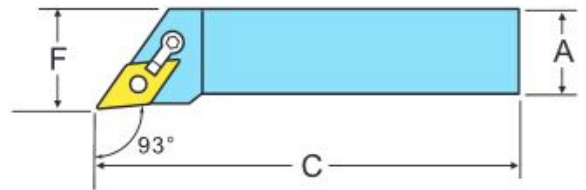

型号	刀体几何尺寸				适用刀片	产品货号		刀垫	锁紧销	压板	双头螺丝	板手
	A	B	F	C		右刀	左刀					
MDJNR/L1616H11	16	16	16	100	DN..1104	2302-0018	2302-1018	D1103B	NL-0414	CL-12		S2 S4
MDJNR/L2020K11	20	20	20	125	DN..1104	2302-0020	2302-1020					
MDJNR/L2020K15	25	25	25	125	DN..1504	2302-0021	2302-1021					
MDJNR/L2525M15	25	25	32	150	DN..1504	2302-0026	2302-1026				XNS-0829	
MDJNR/L3225P15	25	32	32	170	DN..1504	2302-0028	2302-1028	D1504B	NL-0617	CL-30		S2.5 S4
MDJNR/L3232P15	32	32	40	170	DN..1504	2302-0030	2302-1030					
MDJNR/L4025R15	25	40	32	200	DN..1504	2302-0032	2302-1032					

## 英制

MODEL	DIMENSIONS				FOR INSERT	ITEM NO.		SHIM	SHIM PIN	CLAMP	CLAMP SCREW	HEXKEY
	A	B	F	C		RIGHT	LEFT					
MDJNR/L12-3B	0.75	0.75	1.00	4.5	DN..332	2302-5014	2302-6014	D1103B	NL-0414	CL-12		S2,S4
MDJNR/L12-4C	0.75	0.75	1.00	5.0	DN..432	2302-5016	2302-6016					
MDJNR/L16-4C	1.00	1.00	1.25	5.0	DN..432	2302-5018	2302-6018					
MDJNR/L16-4D	1.00	1.00	1.25	6.0	DN..432	2302-5020	2302-6020	D1504B	NL-0617	CL-30	XNS-0829	S2.5 S4
MDJNR/L20-4E	1.25	1.25	1.50	7.0	DN..432	2302-5024	2302-6024					
MDJMR/L24-4F	1.50	1.50	2.00	8.0	DN..432	2302-5028	2302-6028					



# Cutoutil

Metal Carbide Inserts, Turning Tools, Indexable Milling, Carbide Drill

www.cutoutil.com

## 复合式62.5°直头外圆仿形车刀



DNMG, DNMA

**MDPNN 外圆，仿形加工**

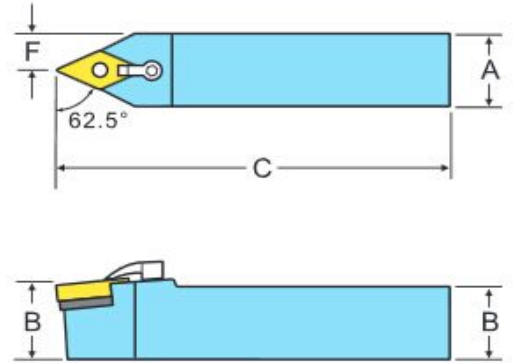

型号	刀体几何尺寸				适用刀片	产品货号					
	A	B	F	C			刀垫	锁紧销	压板	双头螺丝	板手
MDPNN 2525M15	25	25	12.5	150	DN..1506	2303-0008	D1504B	NL-0617	CL-30	XNS-0829	S2.5 S4
MDPNN 3225P15	25	32	12.5	170	DN..1506	2303-0014					
MDPNN 3232P15	32	32	16	170	DN..1506	2303-0018					
MDPNN 4025R15	25	40	12.5	200	DN..1506	2303-0022					

## 英制

MODEL	DIMENSIONS FOR INSERT				ITEM NO.						
	A	B	F	C		SHIM	SHIM PIN	CLAMP	CLAMP SCREW	HEXKEY	
MDPNN 12-4B	0.75	0.75	0.375	4.5	DN..432	2303-5012	D1504B	NL-0617	CL-30	XNS-0829	S2.5 S4
MDPNN 16-4D	1.00	1.00	0.500	6.0	DN..432	2303-5014					
MDPNN 20-4E	1.25	1.25	0.625	7.0	DN..432	2303-5016					

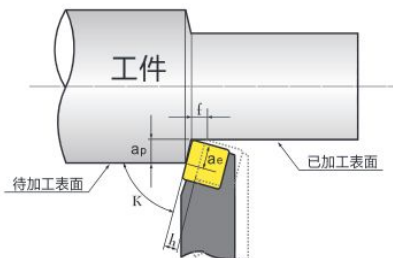

- ap--切深 (深度) (待加工表面和已加工表面之间的距离)
- ae--切削宽度 (被切削部分的长度)
- K--主偏角 (主切削刃和待加工表面构成的角度)
- f--进给量 (工件每转的刀具移动量)
- h--切削厚度 (被切削部分的厚度)
- 已加工表面 (已被加工的工作表面)
- 待加工表面 (加工前的工件表面)





# Cutoutil

Metal Carbide Inserts, Turning Tools, Indexable Milling, Carbide Drill

www.cutoutil.com

## 复合式95°偏头外圆,端面车刀



WNMM,WNMG

## MWLNR/L 外圆, 端面加工

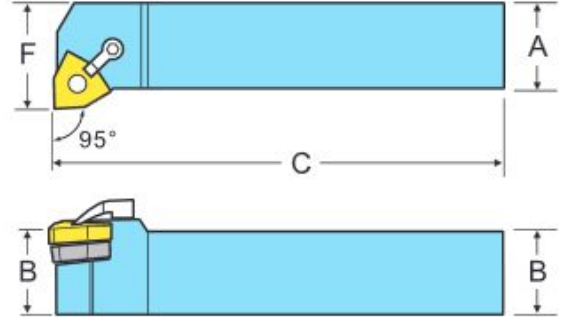

型号	刀体几何尺寸				通用刀片	产品货号		刀垫	锁紧销	压板	双头螺丝	板手
	A	B	F	C		右刀	左刀					
MWLNR/L2020K06	20	20	25	125	WN..0604	2316-5006	2316-6006	W0603B	NL-0414	CL-6	XNS-0520	S2,S2.5
MWLNR/L2020K08	20	20	25	125	WN..0804	2316-5008	2316-6008	W0803B	NL-0617	CL-12	XNS-0829	S2.5 S4
MWLNR/L2520M08	20	25	25	150	WN..0804	2316-5010	2316-6010					
MWLNR/L2525M08	25	25	32	150	WN..0804	2316-5012	2316-6012	W1004B	NL-0822		XNS-0829	S3,S4
MWLNR/L3232P08	32	32	40	170	WN..0804	2316-5014	2316-6014					
MWLNR/L3232P10	32	32	40	170	WN..1006	2316-5016	2316-6016					

## 英制

MODEL	DIMENSIONS				FOR INSERT	ITEM NO.		SHIM	SHIM PIN	CLAMP	CLAMP SCREW	HEXKEY
	A	B	F	C		RIGHT	LEFT					
MWLNR/L 12-3B	0.75	0.75	1.00	4.5	WN..33	2316-0006	2316-1006	W0603B	NL-0414	CL-6	XNS-0520	S2,S2.5
MWLNR/L 12-4C	0.75	0.75	1.00	5.0	WN..43	2316-0010	2316-1010	W0803B	NL-0617	CL-12	XNS-0829	S2.5 S4
MWLNR/L 16-4C	1.00	1.00	1.25	5.0	WN..43	2316-0012	2316-1012					
MWLNR/L 16-4D	1.00	1.00	1.25	6.0	WN..43	2316-0014	2316-1014					
MWLNR/L 20-4E	1.25	1.25	1.50	7.0	WN..43	2316-0016	2316-1016					



# Cutoutil

Metal Carbide Inserts, Turning Tools, Indexable Milling, Carbide Drill

www.cutoutil.com

复合式90°偏头外圆,仿形车刀



RNMA,RNMM

MRGNR/L外圆,仿形加工

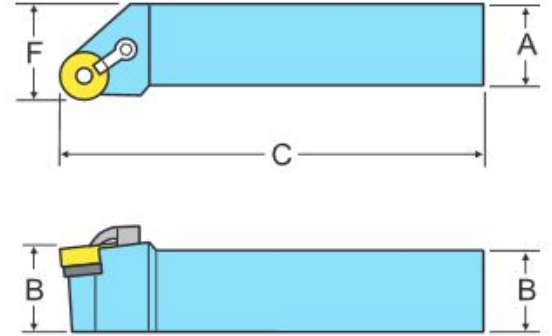

型号	刀体几何尺寸				适用刀片	产品货号		刀垫	锁紧销	压板	双头螺丝	板手
	A	B	F	C		右刀	左刀					
MRGNR/L 2020K10	20	20	25	125	RN..10T3	2305-0010	2305-1010	R1003B	NL-0413			S2,S4
MRGNR/L 2525M10	25	25	32	150	RN..10T3	2305-0012	2305-1012					
MRGNR/L 2525M12	25	25	32	150	RN..1204	2305-0014	2305-1014			CL-12	XNS-0829	
MRGNR/L 3225P12	25	32	32	170	RN..1204	2305-0016	2305-1016	R1203B	NL-0617			S2.5 S4
MRGNR/L 3232P12	32	32	40	170	RN..1204	2305-0018	2305-1018					

英制

MODEL	DIMENSIONS				FOR INSERT	ITEM NO.		SHIM	SHIM PIN	CLAMP	CLAMP SCREW	HEXKEY
	A	B	F	C		RIGHT	LEFT					
MRGNR/L 12-3B	0.75	0.75	1.00	4.5	RN..32	2305-5008	2305-6008	R1003B	NL-0413			S2,S4
MRGNR/L 16-3D	1.00	1.00	1.25	6.0	RN..32	2305-5012	2305-6012					
MRGNR/L 12-4C	0.75	0.75	1.00	5.0	RN..43	2305-5010	2305-6010			CL-12	XNS-0829	
MRGNR/L 16-4D	1.00	1.00	1.25	6.0	RN..43	2305-5014	2305-6014	R1203B	NL-0617			S2.5 S4
MRGNR/L 20-4E	1.25	1.25	1.50	7.0	RN..43	2305-5016	2305-6016					





# Cutoutil

Metal Carbide Inserts, Turning Tools, Indexable Milling, Carbide Drill

www.cutoutil.com

## 复合式45°直头外圆车刀



**MSDNN 外圆，倒角加工**

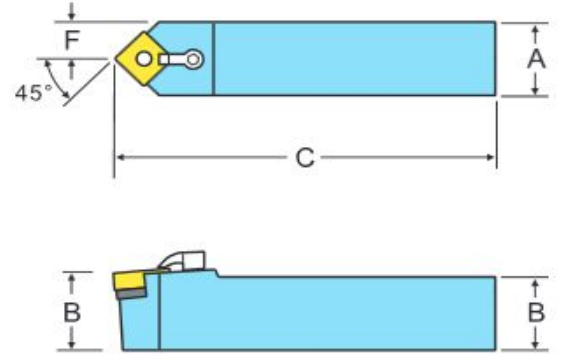

型号	刀体几何尺寸				适用刀片	产品货号					
	A	B	F	C			刀垫	锁紧销	压板	双头螺丝	板手
MSDNN 1616H09	16	16	8	100	SN..0903	2306-0008	S0903B	NL-0413	CL-6	XNS-0520	S2,S2.5
MSDNN 2020K12	20	20	10	125	SN..1204	2306-0010	S1203B	NL-0617	CL-12	XNS-0829	S2.5 S4
MSDNN 2525M12	25	25	12.5	150	SN..1204	2306-0012					
MSDNN 3225P12	25	32	12.5	170	SN..1204	2306-0014					
MSDNN 2525M15	25	25	12.5	150	SN..1506	2306-0016	S1504B	NL-0822	CL-30	S3 S4	
MSDNN 3225P15	25	32	12.5	170	SN..1506	2306-0018					
MSDNN 3232P15	32	32	16	170	SN..1506	2306-0020					
MSDNN 3232P19	32	32	16	170	SN..1906	2306-0022	S1904B	NL-0823	CL-30	S4	
MSDNN 4040R19	40	40	20	200	SN..1906	2306-0024					

## 英制

MODEL	DIMENSIONS FOR				INSERT	ITEM NO.					
	A	B	F	C			SHIM	SHIM PIN	CLAMP	CLAMP SCREW	HEXKEY
MSDNN 08-3A	0.5	0.5	.250	4.0	SN..32	2306-5008	S0903B	NL-0413	CL-6	XNS-0520	S2,S2.5
MSDNN 10-3B	0.625	0.625	.312	4.5	SN..32	2306-5010					
MSDNN 12-3B	0.75	0.75	.375	4.5	SN..32	2306-5012	S1203B	NL-0617	CL-12	XNS-0829	S2.5 S4
MSDNN 12-4C	0.75	0.75	.375	5.0	SN..43	2306-5014					
MSDNN 16-4D	1.00	1.00	.500	6.0	SN..43	2306-5016					
MSDNN 16-5D	1.00	1.00	.500	6.0	SN..54	2306-5018	S1503B	NL-0822	CL-30	S3 S4	
MSDNN 85-5E	1.00	1.25	.500	7.0	SN..54	2306-5024					
MSDNN 20-5E	1.25	1.25	.625	7.0	SN..54	2306-5026	S1904B	NL-0823			CL-30
MSDNN 20-6E	1.25	1.25	.625	7.0	SN..64	2306-5028					
MSDNN 24-6F	1.5	1.5	.750	8.0	SN..64	2306-5030					







# Cutoutil

Metal Carbide Inserts, Turning Tools, Indexable Milling, Carbide Drill

www.cutoutil.com

## 复合式75°偏头外圆车刀



SNMA SNMG SNMM

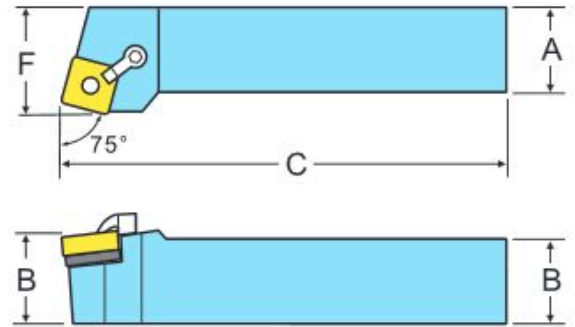

## MSRNR/L 外圆加工

型号	刀体几何尺寸				适用刀片	产品货号		刀垫	锁紧销	压板	双头螺丝	板手
	A	B	F	C		右刀	左刀					
MSRNR/L 1616H09	16	16	17	100	SN..0903	2308-0008	2308-1008	S0903B	NL-0413	CL-6	XNS-0520	S2 S2.5
MSRNR/L 2020K09	20	20	22	125	SN..0903	2308-0010	2308-1010	S1203B	NL-0617	CL-12	XNS-0829	S2.5 S4
MSRNR/L 2020K12	20	20	22	125	SN..1204	2308-0012	2308-1012					
MSRNR/L 2525M12	25	25	27	150	SN..1204	2308-0014	2308-1014	S1504B	NL-0822			S3 S4
MSRNR/L 3225P12	25	32	27	170	SN..1204	2308-0016	2308-1016					
MSRNR/L 2525M15	25	25	27	150	SN..1506	2308-0018	2308-1018	S1904B	NL-0823	CL-30	S4	
MSRNR/L 3225P15	25	32	27	170	SN..1506	2308-0020	2308-1020					
MSRNR/L 3232P15	32	32	35	170	SN..1506	2308-0022	2308-1022					
MSRNR/L 4040R19	40	40	43	200	SN..1906	2308-0024	2308-1024					

## 英制

MODEL	DIMENSIONS				FOR INSERT	ITEM NO.		SHIM	SHIM PIN	CLAMP	CLAMP SCREW	HEXKEY
	A	B	F	C		RIGHT	LEFT					
MSRNR/L 12-3B	0.75	0.75	.880	4.5	SN..33	2308-5008	2308-6008	S0903B	NL-0413	CL-6	XNS-0520	S2,S2.5
MSRNR/L 12-4C	0.75	0.75	.880	5.0	SN..43	2308-5010	2308-6010	S1203B	NL-0617	CL-12	XNS-0829	S2.5 S4
MSRNR/L 16-4D	1.00	1.00	1.130	6.0	SN..43	2308-5012	2308-6012					
MSRNR/L 20-4E	1.25	1.25	1.353	7.0	SN..43	2308-5018	2308-6018	S1504B	NL-0822			S3,S4
MSRNR/L 16-5D	1.00	1.00	1.103	6.0	SN..54	2308-5014	2308-6014					
MSRNR/L 20-6E	1.25	1.25	1.321	7.0	SN..64	2308-5020	2308-6020	S1904B	NL-0823	CL-30		S4







# Cutoutil

Metal Carbide Inserts, Turning Tools, Indexable Milling, Carbide Drill

www.cutoutil.com

## 复合式90°偏头外圆车刀



## MTFNR/L 端面加工

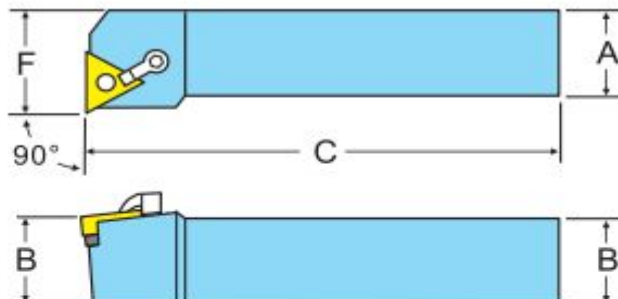

型号	刀体几何尺寸				通用刀片	产品货号		刀垫	锁紧销	压板	双头螺丝	扳手
	A	B	F	C		右刀	左刀					
MTFNR/L 1616H16	16	16	20	100	TN..1604	2310-0008	2310-1008	T1603B	NL-0414	CL-6	XNS-0520	S2 S2.5
MTFNR/L 2020K16	20	20	25	125	TN..1604	2310-0010	2310-1010					
MTFNR/L 2525M16	25	25	32	150	TN..1604	2310-0012	2310-1012					
MTFNR/L 3225P16	25	32	32	170	TN..1604	2310-0014	2310-1014					
MTFNR/L 2525M22	25	25	32	150	TN..2204	2310-0016	2310-1016					
MTFNR/L 3225P22	25	32	32	170	TN..2204	2310-0018	2310-1018	T2203B	NL-0617	CL-12	XNS-0829	S2.5 S4
MTFNR/L 3232P22	32	32	40	170	TN..2204	2310-0020	2310-1020					

## 英制

MODEL	DIMENSIONS				FOR INSERT	ITEM NO.		SHIM	SHIM PIN	CLAMP	CLAMP SCREW	HEXKEY
	A	B	F	C		RIGHT	LEFT					
MTFNR/L 08-2A	.50	.50	.625	4.0	TN..22	2310-5008	2310-6008	-	M-ZX0410	CL-6	XNS-0520	S2 S2.5
MTFNR/L 10-2B	.625	.625	.75	4.5	TN..22	2310-5010	2310-6010					
MTFNR/L 10-3B	.625	.625	.75	4.5	TN..33	2310-5012	2310-6012	T1603B	NL-0414	CL-6	XNS-0520	S2 S2.5
MTFNR/L 12-3C	.75	.75	.75	5.0	TN..33	2310-5014	2310-6014					
MTFNR/L 16-3D	1.00	1.00	1.25	6.0	TN..33	2310-5016	2310-6016					
MTFNR/L 16-4D	1.00	1.00	1.25	6.0	TN..43	2310-5018	2310-6018	T2203B	NL-0617	CL-12	XNS-0829	S2.5 S4
MTFNR/L 20-4E	1.25	1.25	1.50	7.0	TN..43	2310-5020	2310-6020					
MTFNR/L 20-5E	1.25	1.25	1.50	7.0	TN..54	2310-5022	2310-6022	T2704B	NL-0822	CL-12	XNS-0829	S3 S4
MTFNR/L 24-5F	1.50	1.50	2.00	8.0	TN..54	2310-5024	2310-6024					



# Cutoutil

Metal Carbide Inserts, Turning Tools, Indexable Milling, Carbide Drill

www.cutoutil.com

## 复合式90°偏头外圆车刀

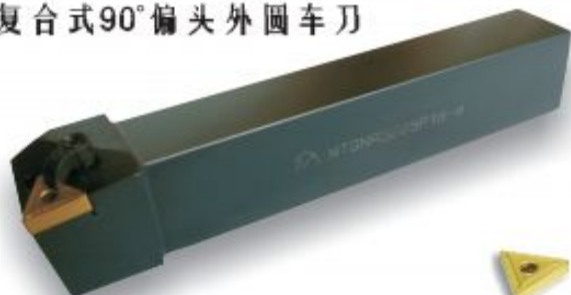

TNMG TNMA

## MTGNR/L 外圆加工

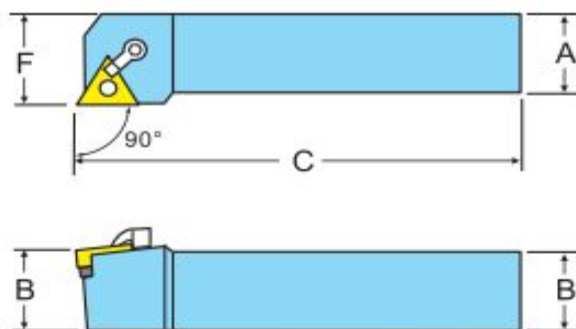

型号	刀体几何尺寸				通用刀片	产品货号		刀垫	锁紧销	压板	双头螺丝	扳手
	A	B	F	C		右刀	左刀					
MTGNR/L 1616H16	16	16	20	100	TN..1604	2311-0008	2311-1008	T1603B	NL-0414	CL-6	XNS-0520	S2 S2.5
MTGNR/L 2020K16	20	20	25	125	TN..1604	2311-0010	2311-1010					
MTGNR/L 2525M16	25	25	32	150	TN..1604	2311-0012	2311-1012					
MTGNR/L 3225P16	25	32	32	170	TN..1604	2311-0014	2311-1014					
MTGNR/L 2525M22	25	25	32	150	TN..2204	2311-0016	2311-1016	T2203B	NL-0617	CL-12	XNS-0829	S2.5 S4
MTGNR/L 3225P22	25	32	32	170	TN..2204	2311-0018	2311-1018					
MTGNR/L 3232P22	32	32	40	170	TN..2204	2311-0020	2311-1020					

## 英制

MODEL	DIMENSIONS				FOR INSERT	ITEM NO.		SHIM	SHIM PIN	CLAMP	CLAMP SCREW	HEXKEY
	A	B	F	C		RIGHT	LEFT					
MTGNR/L 08-2A	.50	.50	.625	4.0	TN..22	2311-5008	2311-6008	T1603B	M-2X0410	CL-6	XNS-0520	S2 S2.5
MTGNR/L 10-2B	.625	.625	.75	4.5	TN..22	2311-5010	2311-6010					
MTGNR/L 10-3A	.625	.625	.875	4.0	TN..33	2311-5012	2311-6012					
MTGNR/L 10-3B	.625	.625	.875	4.5	TN..33	2311-5014	2311-6014					
MTGNR/L 12-3C	.75	.75	1.00	5.0	TN..33	2311-5016	2311-6016	T2203B	NL-0617	CL-12	XNS-0829	S2.5 S4
MTGNR/L 16-3C	1.00	1.00	1.25	5.0	TN..33	2311-5020	2311-6020					
MTGNR/L 16-3D	1.00	1.00	1.25	6.0	TN..33	2311-5022	2311-6022					
MTGNR/L 16-4D	1.00	1.00	1.25	6.0	TN..43	2311-5024	2311-6024					
MTGNR/L 85-4E	1.00	1.25	1.25	7.0	TN..43	2311-5026	2311-6026	T2704B	NL-0822		XNS-0829	S3 S4
MTGNR/L 86-4F	1.00	1.50	1.25	8.0	TN..43	2311-5028	2311-6028					
MTGNR/L 20-4E	1.25	1.25	1.50	7.0	TN..43	2311-5032	2311-6032					
MTGNR/L 20-5E	1.25	1.25	1.50	7.0	TN..54	2311-5034	2311-6034					
MTGNR/L 24-5F	1.50	1.50	2.00	8.0	TN..54	2311-5036	2311-6036					





# Cutoutil

Metal Carbide Inserts, Turning Tools, Indexable Milling, Carbide Drill

www.cutoutil.com

## 复合式93°偏头外圆车刀



MTJNR/L 外圆加工

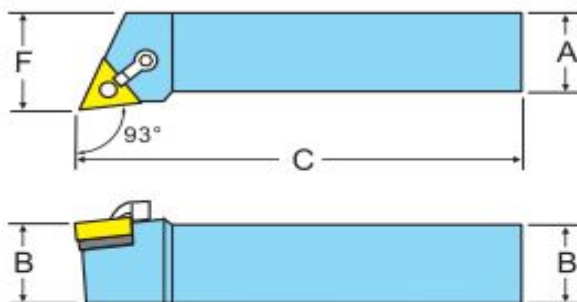

型号	刀体几何尺寸				适用刀片	产品货号		刀垫	锁紧销	压板	双头螺丝	板手
	A	B	F	C		右刀	左刀					
MTJNR/L 1616H16	16	16	20	100	TN..1604	2312-0008	2312-1008	T1603B	NL-0414	CL-6	XNS-0520	S2 S2.5
MTJNR/L 2020K16	20	20	25	125	TN..1604	2312-0010	2312-1010					
MTJNR/L 2525M16	25	25	32	150	TN..1604	2312-0012	2312-1012					
MTJNR/L 3225P16	25	32	32	170	TN..1604	2312-0014	2312-1014	T2203B	NL-0617	CL-12	XNS-0829	S2.5 S4
MTJNR/L 2525M22	25	25	32	150	TN..2204	2312-0016	2312-1016					
MTJNR/L 3225P22	25	32	32	170	TN..2204	2312-0018	2312-1018					
MTJNR/L 3232P22	32	32	40	170	TN..2204	2312-0020	2312-1020					

## 英制

MODEL	DIMENSIONS				FOR INSERT	ITEM NO.		SHIM	SHIM PIN	CLAMP	CLAMP SCREW	HEXKEY
	A	B	F	C		RIGHT	LEFT					
MTJNR/L 12-3C	0.75	0.75	1.00	5.0	TN..32	2312-5008	2312-6008	T1603B	NL-0414	CL-6	XNS-0520	S2 S2.5
MTJNR/L 16-3D	1.00	1.00	1.25	6.0	TN..32	2312-5010	2312-6010					
MTJNR/L 16-4D	1.00	1.00	1.25	6.0	TN..43	2312-5012	2312-6012	T2203B	NL-0617	CL-12	XNS-0829	S2.5 S4
MTJNR/L 20-4E	1.25	1.25	1.50	7.0	TN..43	2312-5016	2312-6016					
MTJNR/L 20-5E	1.25	1.25	1.50	7.0	TN..54	2312-5018	2312-6018	T2704B	NL-0822			S3,S4



# Cutoutil

Metal Carbide Inserts, Turning Tools, Indexable Milling, Carbide Drill

www.cutoutil.com

## 复合式60°直头外圆车刀



**MTENN** 外圆·仿形加工

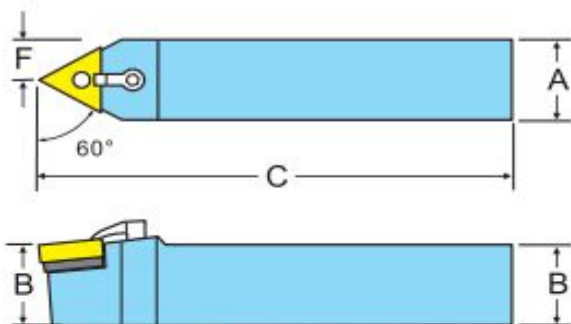

型号	刀体几何尺寸				适用刀片	产品货号					
	A	B	F	C			刀垫	锁紧销	压板	双头螺丝	扳手
MTENN 2020K16	20	20	10	125	TN..1604..	2313-0012	T1603B	NL-0414	CL-6	XNS-0520	S2 S2.5
MTENN 2525M16	25	25	12.5	150	TN..1604..	2313-0014					
MTENN 3225P16	25	32	12.5	170	TN..1604..	2313-0016					
MTENN 2525M22	25	25	12.5	150	TN..2204..	2313-0018					
MTENN 3225P22	25	32	12.5	170	TN..2204..	2313-0020	T2203B	NL-0617	CL-12	XNS-0829	S2.5 S4
MTENN 3232P22	32	32	16	170	TN..2204..	2313-0022					

## 英制

MODEL	DIMENSIONS				FOR INSERT	ITEM NO.					
	A	B	F	C			SHIM	SHIM PIN	CLAMP	CLAMP SCREW	HEXKEY
MTENN 08-2A	.5	.5	.250	4.0	TN..22.	2313-5012	—	M-ZX0410			
MTENN 10-3B	.625	.625	.312	4.5	TN..32.	2313-5014	T1603B	NL-0414	CL-6	XNS-0520	S2 S2.5
MTENN 12-3C	.75	.75	.375	5.0	TN..32.	2313-5016					
MTENN 12-4C	.75	.75	.375	5.0	TN..43.	2313-5018					
MTENN 16-4D	1.00	1.00	.500	6.0	TN..43.	2313-5020	T2203B	NL-0617			S2.5 S4
MTENN 20-5E	1.25	1.25	.625	7.0	TN..54.	2313-5022			CL-12	XNS-0829	
MTENN 24-5E	1.5	1.5	.750	7.0	TN..54.	2313-5024	T2704B	NL-0822			S3 S4





# Cutoutil

Metal Carbide Inserts, Turning Tools, Indexable Milling, Carbide Drill

www.cutoutil.com

## 复合式90°直头端面车刀





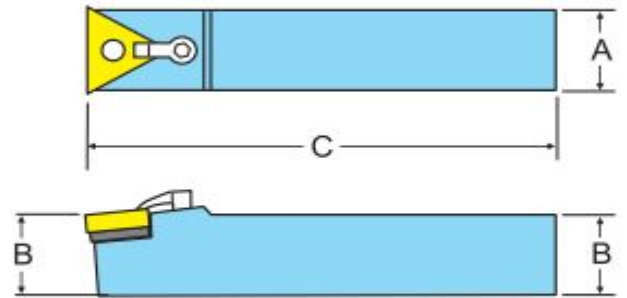

TNMG TNMA



## MTCNN 端面加工

英制

MODEL	DIMENSIONS FOR				INSERT	ITEM NO.					
	A	B	F	C			SHIM	SHIM PIN	CLAMP	CLAMP SCREW	HEXKEY
MTCNN 08-3A	.50	.50	—	4.0	TN..32.	2317-5008	—	NL-0410	CL-6	XNS-0520	S2 S2.5
MTCNN 44-3D	.50	1.00	—	6.0	TN..32.	2317-5010	T1603B	NL-0414	CL-6	XNS-0520	S2 S2.5
MTCNN 12-4C	.75	.75	—	5.0	TN..43.	2317-0512	—	—	CL-6	XNS-0520	S2 S2.5
MTCNN 64-4D	.75	1.00	—	6.0	TN..43.	2317-5014	T2203B	NL-0617	CL-12	XNS-0829	S2.5 S4
MTCNN 66-4E	.75	1.50	—	7.0	TN..43.	2317-5016	—	—	CL-12	XNS-0829	S2.5 S4



# Cutoutil

Metal Carbide Inserts, Turning Tools, Indexable Milling, Carbide Drill

www.cutoutil.com

## 复合式93°偏头外圆仿形车刀



**MVJNR/L 外圆·仿形加工**

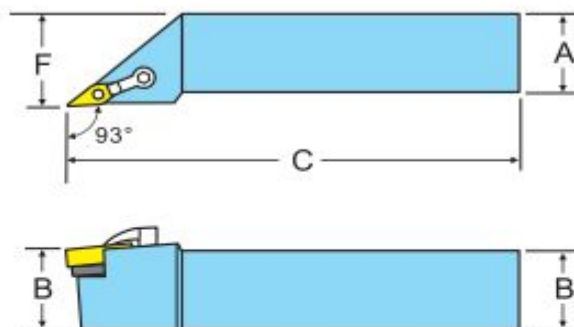

型号	刀体几何尺寸				适用刀片	产品货号		刀垫	锁紧销	压板	双头螺丝	扳手
	A	B	F	C		右刀	左刀					
MVJNR/L 1616H16	16	16	20	100	VN..1604..	2314-0008	2314-1008					
MVJNR/L 2020K16	20	20	25	125	VN..1604..	2314-0010	2314-1010					
MVJNR/L 2525M16	25	25	32	150	VN..1604..	2314-0012	2314-1012	V1603B	NL-0414	CL-30	XNS-0829	S2 S4
MVJNR/L 3225P16	25	32	32	170	VN..1604..	2314-0014	2314-1014					
MVJNR/L 3232P16	32	32	40	170	VN..1604..	2314-0016	2314-1016					

## 英制

MODEL	DIMENSIONS				FOR INSERT	ITEM NO.		SHIM	SHIM PIN	CLAMP	CLAMP SCREW	HEXKEY
	A	B	F	C		RIGHT	LEFT					
MVJNR/L 12-3C	0.75	0.75	1.00	5.0	VN..33..	2314-5008	2314-6008					
MVJNR/L 16-3C	1.00	1.00	1.25	5.0	VN..33..	2314-5012	2314-6012					
MVJNR/L 16-3D	1.00	1.00	1.25	6.0	VN..33..	2314-5014	2314-6014	V1603B	NL-0414	CL-30		S2 S4
MVJNR/L 20-3E	1.25	1.25	1.50	7.0	VN..33..	2314-5018	2314-6018					
MVJNR/L 24-3F	1.50	1.50	2.00	8.0	VN..33..	2314-5022	2314-6022					
MVJNR/L 12-4D	0.75	0.75	1.00	6.0	VN..43..	2314-5010	2314-6010				XNS-0829	
MVJNR/L 16-4D	1.00	1.00	1.25	6.0	VN..43..	2314-5016	2314-6016					
MVJNR/L 20-4E	1.25	1.25	1.50	7.0	VN..43..	2314-5020	2314-6020	V2203B	NL-0617	CL-36		S2.5 S4
MVJNR/L 24-4E	1.50	1.50	2.00	7.0	VN..43..	2314-5024	2314-6024					
MVJNR/L 85-4E	1.00	1.25	1.25	7.0	VN..43..	2314-5026	2314-6026					
MVJNR/L 86-4F	1.00	1.50	1.25	8.0	VN..43..	2314-5028	2314-6028					





# Cutoutil

Metal Carbide Inserts, Turning Tools, Indexable Milling, Carbide Drill

www.cutoutil.com

## 复合式72.5°直头外圆仿形车刀



### MVVNN 仿形，外圆加工

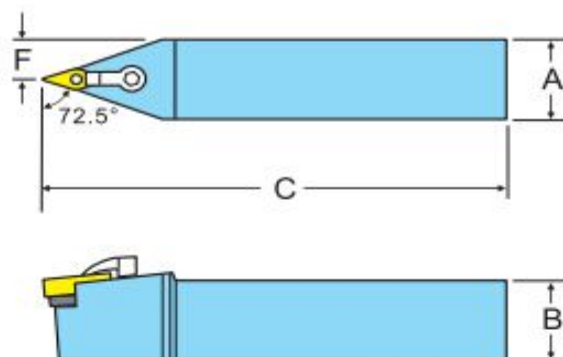

型号	刀体几何尺寸				适用刀片	产品货号					
	A	B	F	C			刀垫	锁紧销	压板	双头螺丝	板手
MVVNN 2020K16	20	20	10	125	VN..1604..	2315-0010	V1603B	NL-0414	CL-30	XNS-0829	S2 S4
MVVNN 2525M16	25	25	12.5	150	VN..1604..	2315-0012					
MVVNN 3225P16	25	32	12.5	170	VN..1604..	2315-0014					
MVVNN 3232P16	32	32	16	170	VN..1604..	2315-0016					

### 英制

MODEL	DIMENSIONS				FOR INSERT	ITEM NO.					
	A	B	F	C			SHIM	SHIM PIN	CLAMP	CLAMP SCREW	HEXKEY
MVVNN 12-3C	.75	.75	.375	5.0	VN..33..	2315-5010					
MVVNN 16-3C	1.00	1.00	.50	5.0	VN..33..	2315-5014	V1603B	NL-0414	CL-30		S2 S4
MVVNN 16-3D	1.00	1.00	.50	6.0	VN..33..	2315-5016				XNS-0829	
MVVNN 20-3E	1.25	1.25	.625	7.0	VN..33..	2315-5020					
MVVNN 12-4D	.75	.75	.375	6.0	VN..43..	2315-5012					
MVVNN 16-4D	1.00	1.00	.50	6.0	VN..43..	2315-5018	V2203B	NL-0617	CL-36		S2.5 S4
MVVNN 20-4E	1.25	1.25	.625	7.0	VN..43..	2315-5020					



# Cutoutil

Metal Carbide Inserts, Turning Tools, Indexable Milling, Carbide Drill

www.cutoutil.com

## 复合式90°偏头外圆车刀



## MCGNR/L外圆加工

CNMG, CNMA, CNMM

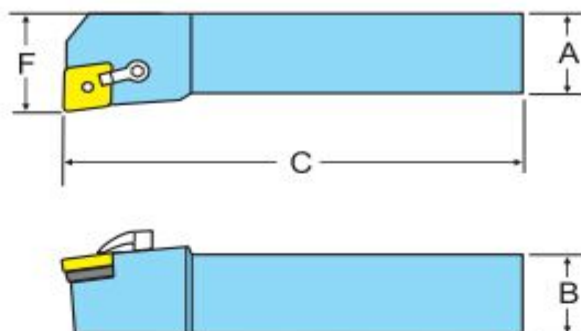

型号	刀体几何尺寸				通用刀片	产品货号		刀垫	锁紧销	压板	双头螺丝	板手
	A	B	F	C		右刀	左刀					
MCGNR/L 2020K12	20	20	25	125	CN..1204..	2320-0012	2320-1012	C1203B	NL-0617			S2.5 S4
MCGNR/L 2525M12	25	25	32	150	CN..1204..	2320-0014	2320-1014					
MCGNR/L 2525M16	25	25	32	170	CN..1606..	2320-0016	2320-1016			CL-12		
MCGNR/L 3225P16	25	32	32	170	CN..1606..	2320-0018	2320-1018	C1603B	NL-0822		XNS-0829	S3 S4
MCGNR/L 3232P16	32	32	40	170	CN..1606..	2320-0020	2320-1020					
MCGNR/L 3232P19	32	32	40	170	CN..1906..	2320-0022	2320-1022					
MCGNR/L 4040R19	40	40	50	200	CN..1906..	2320-0024	2320-1024	C1904B	NL-0823	CL30		S4

## 英制

MODEL	DIMENSIONS FOR INSERT				ITEM NO.	RIGHT	LEFT	SHIM	SHIM PIN	CLAMP	CLAMP SCREW	HEXKEY
	A	B	F	C								
MCGNR/L 12-4C	0.75	0.75	1.00	5.0	CN..432	2320-5012	2320-6012					
MCGNR/L 16-4C	1.00	1.00	1.25	5.0	CN..432	2320-5014	2320-6014					
MCGNR/L 16-4D	1.00	1.00	1.25	6.0	CN..432	2320-5016	2320-6016	C1203B	NL-0617			S2.5 S4
MCGNR/L 85-4E	1.00	1.25	1.25	7.0	CN..432	2320-5018	2320-6018			CL-12	XNS-0829	
MCGNR/L 20-4E	1.25	1.25	1.50	7.0	CN..432	2320-5020	2320-6020					
MCGNR/L 16-5D	1.00	1.00	1.25	6.0	CN..543	2320-5022	2320-6022					
MCGNR/L 20-5E	1.25	1.25	1.50	7.0	CN..543	2320-5024	2320-6024	C1603B	NL-0822			S3 S4







# Cutoutil

Metal Carbide Inserts, Turning Tools, Indexable Milling, Carbide Drill

www.cutoutil.com

## 复合式90°偏头外圆仿形车刀



**MWGNR/L 外圆加工**

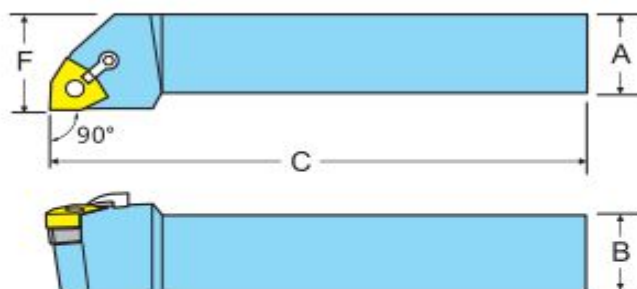

型号	刀体几何尺寸				通用刀片	产品货号		刀垫	锁紧销	压板	双头螺丝	扳手
	A	B	F	C		右刀	左刀					
MWGNR/L 2020K08	20	20	25	125	WN..0804..	2326-0010	2326-1010					S2.5 S4
MWGNR/L 2520M08	20	25	25	150	WN..0804..	2326-0012	2326-1012	W0803B	NL-0617			
MWGNR/L 2525M08	25	25	32	150	WN..0804..	2326-0014	2326-1014			CL-12	XNS-0829	
MWGNR/L 2525M10	25	25	32	150	WN..1006..	2326-0016	2326-1016					
MWGNR/L 3225P10	25	32	32	170	WN..1006..	2326-0018	2326-1018	W1004B	NL-0822			S3 S4
MWGNR/L 4032R10	32	40	40	200	WN..1006..	2326-0020	2326-1020					

## 英制

MODEL	DIMENSIONS FOR				INSERT	ITEM NO.		SHIM	SHIM PIN	CLAMP	CLAMP SCREW	HEXKEY
	A	B	F	C		RIGHT	LEFT					
MWGNR/L 12-3B	.75	.75	1.00	4.5	WN..33..	2326-5010	2326-6010	W0603B	NL-0414	CL-6	XNS-0520	S2,S2.5
MWGNR/L 12-4C	.75	.75	1.00	5.0	WN..43..	2326-5012	2326-6012					
MWGNR/L 16-4C	1.00	1.00	1.25	6.0	WN..43..	2326-5014	2326-6014	W0803B	NL-0617	CL-12	XNS-0829	S2.5 S4
MWGNR/L 16-4D	1.00	1.00	1.25	6.0	WN..43..	2326-5016	2326-6016					
MWGNR/L 20-4E	1.00	1.00	1.50	7.0	WN..43..	2326-5018	2326-6018					



# Cutoutil

Metal Carbide Inserts, Turning Tools, Indexable Milling, Carbide Drill

www.cutoutil.com

## 复合式75°直头外圆车刀



## MCBNR/L 外圆加工

CNMG,CNMA,CNMM

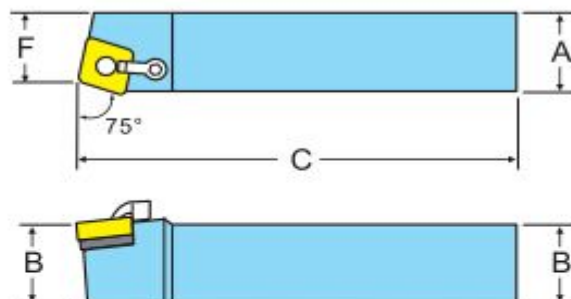

型号	刀体几何尺寸				适用刀片	产品货号		刀垫	锁紧销	压板	双头螺丝	扳手
	A	B	F	C		右刀	左刀					
MCBNR/L 2020K12	20	20	17	125	CN..1204..	2323-0010	2323-1010	C1203B	NL-0617			S2.5 S4
MCBNR/L 2525M12	25	25	22	150	CN..1204..	2323-0012	2323-1012					
MCBNR/L 2525M16	25	25	22	150	CN..1606..	2323-0014	2323-1014			CL-12		
MCBNR/L 3225P16	25	32	22	170	CN..1606..	2323-0016	2323-1016	C1604B	NL-0822		XNS-0829	S3 S4
MCBNR/L 3232P16	32	32	27	170	CN..1606..	2323-0018	2323-1018					
MCBNR/L 3232P19	32	32	27	170	CN..1906..	2323-0020	2323-1020	C1904B	NL-0823	CL-30		S4
MCBNR/L 4040R19	40	40	35	200	CN..1906..	2323-0022	2323-1022					

## 英制

MODEL	DIMENSIONS				FOR INSERT	ITEM NO.		SHIM	SHIM PIN	CLAMP	CLAMP SCREW	HEXKEY
	A	B	F	C		RIGHT	LEFT					
MCBNR/L 12-4C	0.75	0.75	.63	5.0	CN..432	2323-5010	2323-6010					
MCBNR/L 16-4C	1.00	1.00	.88	5.0	CN..432	2323-5012	2323-6012					
MCBNR/L 16-4D	1.00	1.00	.88	6.0	CN..432	2323-5014	2323-6014					
MCBNR/L 85-4E	1.00	1.25	.88	7.0	CN..432	2323-5016	2323-6016	C1203B	NL-0617	CL-12		S2.5 S4
MCBNR/L 20-4D	1.25	1.25	1.05	6.0	CN..432	2323-5018	2323-6018				XNS-0829	
MCBNR/L 20-4E	1.00	1.00	1.05	7.0	CN..432	2323-5020	2323-6020					
MCBNR/L 20-5E	1.25	1.25	1.05	7.0	CN..543	2323-5022	2323-6022	C1604B	NL-0822			S3,S4
MCBNR/L 24-6F	1.50	1.50	1.30	8.0	CN..643	2323-5024	2323-6024	C1904B	NL-0823	CL-30		S4





# Cutoutil

Metal Carbide Inserts, Turning Tools, Indexable Milling, Carbide Drill

www.cutoutil.com

## 复合式107.5°偏头外圆仿形车刀

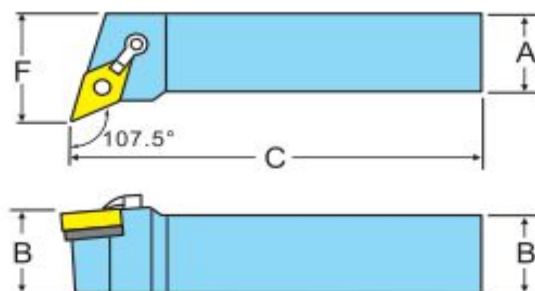

## MDQNR/L 外圆、仿形加工

型号	刀体几何尺寸				适用刀片	产品货号		刀垫	锁紧销	压板	双头螺丝	板手
	A	B	F	C		右刀	左刀					
MDQNR/L 2020K15	20	20	25	125	DN..1504..	2324-0012	2324-1012	D1504B	NL-0617	CL-30	XNS-0829	S2.5 S4
MDQNR/L 2525M15	25	25	32	150	DN..1504..	2324-0014	2324-1014					
MDQNR/L 3225P15	25	32	32	170	DN..1504..	2324-0016	2324-1016					
MDQNR/L 3232P15	32	32	40	170	DN..1504..	2324-0018	2324-1018					

## 英制

MODEL	DIMENSIONS				FOR INSERT	ITEM NO.		SHIM	SHIM PIN	CLAMP	CLAMP SCREW	HEXKEY
	A	B	F	C		RIGHT	LEFT					
MDQNR/L 12-4C	.75	.75	1.0	5.0	DN..43..	2324-5012	2324-6012	D1504B	NL-0617	CL-30	XNS-0829	S2.5 S4
MDQNR/L 16-4D	1.00	1.00	1.25	6.0	DN..43..	2324-5014	2324-6014					
MDQNR/L 20-4E	1.00	1.00	1.50	7.0	DN..53..	2324-5016	2324-6016					



# Cutoutil

Metal Carbide Inserts, Turning Tools, Indexable Milling, Carbide Drill

www.cutoutil.com

## 复合式75°直头外圆车刀



CNMG, CNMA, CNMM

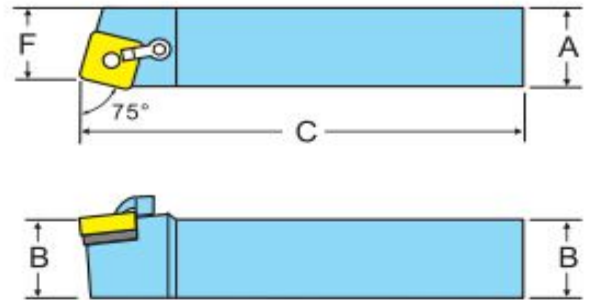

## MSBNR/L 外圆加工

型号	刀体几何尺寸				通用刀片	产品货号		刀垫	锁紧销	压板	双头螺丝	扳手
	A	B	F	C		右刀	左刀					
MSBNR/L 2020K12	20	20	17	125	SN..1204..	2325-0010	2325-1010	S1203B	NL-0617	CL-12	XNS-0829	S2.5 S4
MSBNR/L 2520M12	20	25	22	150	SN..1204..	2325-0012	2325-1012					
MSBNR/L 2525M12	25	25	22	150	SN..1204..	2325-0014	2325-1014	S1504B	NL-0822	CL-30	XNS-0829	S3 S4
MSBNR/L 2525M15	25	25	22	150	SN..1506..	2325-0016	2325-1016					
MSBNR/L 3225P15	25	32	22	170	SN..1506..	2325-0018	2325-1018	S1904B	NL-0823	CL-30	XNS-0829	S4
MSBNR/L 3232P15	32	32	27	170	SN..1506..	2325-0020	2325-1020					
MSBNR/L 3232P19	32	32	27	170	SN..1906..	2325-0022	2325-1022	S1904B	NL-0823	CL-30	XNS-0829	S4
MSBNR/L 4040R19	40	40	35	200	SN..1906..	2325-0024	2325-1024					

## 英制

MODEL	DIMENSIONS				FOR INSERT	ITEM NO.		SHIM	SHIM PIN	CLAMP	CLAMP SCREW	HEXKEY
	A	B	F	C		RIGHT	LEFT					
MSBNR/L 12-4C	0.75	0.75	.63	5.0	SN..432	2325-5010	2325-6010	S1203B	NL-0617	CL-12	XNS-0829	S2.5 S4
MSBNR/L 16-4C	1.00	1.00	.88	5.0	SN..432	2325-5012	2325-6012					
MSBNR/L 16-4D	1.00	1.00	.88	6.0	SN..432	2325-5014	2325-6014	S1504B	NL-0822	CL-30	XNS-0829	S3, S4
MSBNR/L 85-4E	1.00	1.25	.88	7.0	SN..432	2325-5016	2325-6016					
MSBNR/L 20-4D	1.25	1.25	1.05	6.0	SN..432	2325-5018	2325-6018	S1904B	NL-0823	CL-30	XNS-0829	S4
MSBNR/L 20-4E	1.25	1.25	1.05	7.0	SN.,432	2325-5020	2325-6020					
MSBNR/L 20-5E	1.25	1.25	1.05	7.0	SN.,543	2325-5022	2325-6022	S1904B	NL-0823	CL-30	XNS-0829	S4
MSBNR/L 24-6F	1.50	1.50	1.30	8.0	SN.,643	2325-5024	2325-6024					



# Cutoutil

Metal Carbide Inserts, Turning Tools, Indexable Milling, Carbide Drill

[www.cutoutil.com](http://www.cutoutil.com)



A series of horizontal dashed lines for writing, starting from the top of the page and extending to the bottom.





# Cutoutil

Metal Carbide Inserts, Turning Tools, Indexable Milling, Carbide Drill

www.cutoutil.com

95°直头外圆，端面车刀



CNMG, CNMA, CNMM

DCLNR/L 车削加工，外圆，端面加工

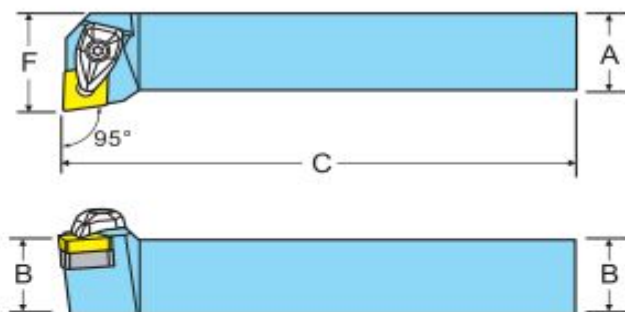

型号	刀体几何尺寸				通用刀片	产品货号		刀垫	刀垫螺钉	压板	压板螺丝	扳手，卡圆
	A	B	F	C		右刀	左刀					
DCLNR/L 2020K12	20	20	25	125	CN..1204..	2330-0012	2330-1012					
DCLNR/L 2525M12	25	25	32	150	CN..1204..	2330-0014	2330-1014	C1203B	LYM6X10			
DCLNR/L 3225P12	25	32	32	170	CN..1204..	2330-0016	2330-1016			DLM-4		
DCLNR/L 2525M16	25	25	32	150	CN..1606..	2330-0017	2330-1017				LE-06	S4 E4
DCLNR/L 3225P16	25	32	32	170	CN..1606..	2330-0018	2330-1018	C1604B	LYM8X10			
DCLNR/L 3232P16	32	32	40	170	CN..1606..	2330-0020	2330-1020					
DCLNR/L 3232P19	32	32	40	170	CN..1906..	2330-0022	2330-1022	C1904B	LYM10X12	DLM-2		
DCLNR/L 4040R19	40	40	50	200	CN..1906..	2330-0024	2330-1024					

英制

MODEL	DIMENSIONS				FOR INSERT	ITEM NO.		SHIM	SHIM SCREW	CLAMP	CLAMP SCREW	HEXKEY CLIPS
	A	B	F	C		RIGHT	LEFT					
DCLNR/L 12-4C	0.75	0.75	1.00	5.0	CN..43..	2330-5012	2330-6012					
DCLNR/L 16-4C	1.00	1.00	1.25	5.0	CN..43..	2330-5014	2330-6014					
DCLNR/L 16-4D	1.00	1.00	1.25	6.0	CN..43..	2330-5016	2330-6016	C1203B	LYM6X10			
DCLNR/L 20-4D	1.25	1.25	1.50	6.0	CN..43..	2330-5018	2330-6018			DLM-4		
DCLNR/L 24-4F	1.50	1.50	2.00	8.0	CN..43..	2330-5020	2330-6020				LE-06	S4 E4
DCLNR/L 16-5D	1.00	1.00	1.25	6.0	CN..54..	2330-5022	2330-6022	C1604B	LYM8X10			
DCLNR/L 20-5E	1.25	1.25	1.50	7.0	CN..54..	2330-5024	2330-6024					
DCLNR/L 20-6E	1.25	1.25	1.50	7.0	CN..64..	2330-5028	2330-6028	C1904B	LYM10X12	DLM-2		
DCLNR/L 24-6F	1.50	1.50	2.00	8.0	CN..64..	2330-5030	2330-6030					



# Cutoutil

Metal Carbide Inserts, Turning Tools, Indexable Milling, Carbide Drill

www.cutoutil.com

## 90° 偏头外圆刀



CNMG, CNMA, CNMM

DCGNR/L 外圆加工

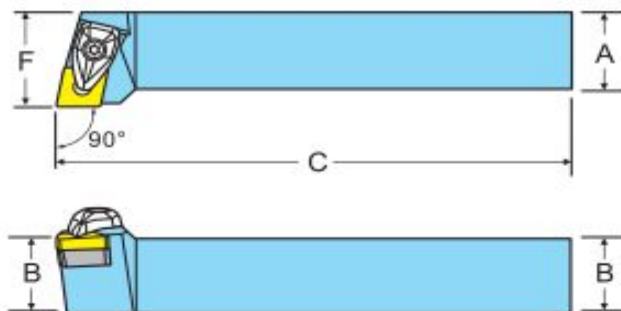

型号	刀体几何尺寸				适用刀片	产品货号		刀垫	刀垫螺钉	压板	压板螺丝	扳手, 卡圈
	A	B	F	C		右刀	左刀					
DCGNR/L 2020K12	20	20	25	125	CN..1204..	2337-0010	2337-1010	C1203B	LYM6x10			
DCGNR/L 2525M12	25	25	32	150	CN..1204..	2337-0012	2337-1012					
DCGNR/L 2525M16	25	25	32	170	CN..1606..	2337-0014	2337-1014			DLM-4		
DCGNR/L 3225P16	25	32	32	170	CN..1606..	2337-0016	2337-1016	C1604B	LYM8x10		LE-06	S4 E4
DCGNR/L 3232P16	32	32	40	170	CN..1606..	2337-0018	2337-1018					
DCGNR/L 3232P19	32	32	40	170	CN..1906..	2337-0020	2337-1020	C1904B	LYM10x12	DLM-2		
DCGNR/L 4040R19	40	40	50	200	CN..1906..	2337-0022	2337-1022					

## 英制

MODEL	DIMENSIONS				FOR INSERT	ITEM NO.		SHIM	SHIM SCREW	CLAMP	CLAMP SCREW	HEXKEY CLIPS
	A	B	F	C		RIGHT	LEFT					
DCGNR/L 12-4C	0.75	0.75	1.00	5.0	CN..432	2337-5010	2337-6010	C1203B	LYM6x10			
DCGNR/L 16-4D	1.00	1.00	1.25	6.0	CN..432	2337-5012	2337-6012			DLM-4	LE-06	S4 E4
DCGNR/L 16-5D	1.00	1.00	1.25	6.0	CN..542	2337-5014	2337-6014	C1604B	LYM8x10			
DCGNR/L 85-5E	1.00	1.25	1.25	7.0	CN..542	2337-5016	2337-6016					



# Cutoutil

Metal Carbide Inserts, Turning Tools, Indexable Milling, Carbide Drill

www.cutoutil.com

## 93° 偏头外圆车刀



DNMG, DNMA, DNMM

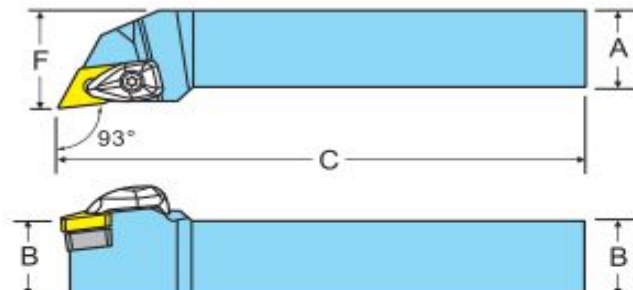

## DDJNR/L 外圆、仿形加工

型号	刀体几何尺寸				适用刀片	产品货号		刀垫	刀垫螺钉	压板	压板螺丝	扳手·卡圈
	A	B	F	C		右刀	左刀					
DDJNR/L 2020K15	20	20	25	125	DNM.1504..	2332-0018	2332-1018					
DDJNR/L 2525M15	25	25	32	150	DNM.1504..	2332-0020	2332-1020					
DDJNR/L 3225P15	25	32	32	170	DNM.1504..	2332-0022	2332-1022	D1504B	LYM6X10	DLM-4	LE-06	S4 E4
DDJNR/L 3232P15	32	32	40	170	DNM.1504..	2332-0024	2332-1024					
DDJNR/L 4025R15	25	40	32	200	DNM.1504..	2332-0026	2332-1026					

## 英制

MODEL	DIMENSIONS				FOR INSERT	ITEM NO.		SHIM	SHIM SCREW	CLAMP	CLAMP SCREW	HEXKEY CLIPS
	A	B	F	C		RIGHT	LEFT					
DDJNR/L 12-4C	0.75	0.75	1.00	5.0	DNM.43..	2332-5014	2332-6014					
DDJNR/L 16-4D	1.00	1.00	1.25	6.0	DNM.43..	2332-5018	2332-6018	D1504B	LYM6x10	DLM-4	LE-06	S4 E4
DDJNR/L 20-4E	1.25	1.25	1.50	7.0	DNM.43..	2332-5022	2332-6022					

## 车刀术语

### 切削速度

$$V = \frac{\pi \times D \times n}{1000} \text{ (M/min)}$$

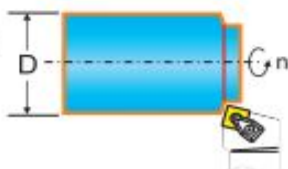

- V: 切削速度
- D: 被加工工件直径
- n: 主轴转速
- π: 圆周率

### 进给量

$$f = \frac{F}{n} \text{ (mm/rev)}$$

- f: 每转进给
- F: 每分钟进给
- n: 主轴转速





# Cutoutil

Metal Carbide Inserts, Turning Tools, Indexable Milling, Carbide Drill

www.cutoutil.com

## 45° 偏头外圆端面车刀

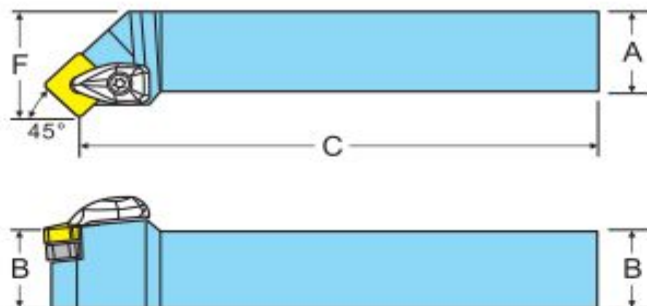

**DSSNR/L** 端面，外圆加工

型号	刀体几何尺寸				适用刀片	产品货号		刀垫	刀垫螺钉	压板	压板螺丝	扳手·卡圈
	A	B	F	C		右刀	左刀					
DSSNR/L 2020K12	20	20	25	125	SNM.1204..	2336-0012	2336-1012	S1203B	LYM6X10	DLM-4	LE-06	S4 E4
DSSNR/L 2520K12	20	25	25	150	SNM.1204..	2336-0013	2336-1013					
DSSNR/L 2525M12	25	25	32	150	SNM.1204..	2336-0014	2336-1014					
DSSNR/L 3225P12	25	32	32	170	SNM.1204..	2336-0016	2336-1016	S1504B	LYM8X10	DLM-4	LE-06	S4 E4
DSSNR/L 2525M15	25	25	32	150	SNM.1506..	2336-0018	2336-1018					
DSSNR/L 3225P15	25	32	32	170	SNM.1506..	2336-0020	2336-1020					
DSSNR/L 3232P15	32	32	40	170	SNM.1506..	2336-0022	2336-1022	S1904B	LYM10X12	DLM-2	LE-06	S4 E4
DSSNR/L 3232P19	32	32	40	170	SNM.1906..	2336-0024	2336-1024					
DSSNR/L 4040R19	40	40	50	200	SNM.1906..	2336-0026	2336-1026					

## 英制

MODEL	DIMENSIONS				FOR INSERT	ITEM NO.		SHIM	SHIM SCREW	CLAMP	CLAMP SCREW	HEXKEY CLIPS
	A	B	F	C		RIGHT	LEFT					
DSSNR/L 12-4C	0.75	0.75	1.00	5.0	SNM.43..	2336-5008	2336-6008	S1203B	LYM6X10	DLM-4	LE-06	S4 E4
DSSNR/L 16-4D	1.00	1.00	1.25	6.0	SNM.43..	2336-5012	2336-6012					
DSSNR/L 16-5D	1.00	1.00	1.25	6.0	SNM.54..	2336-5013	2336-6013					
DSSNR/L 20-6E	1.25	1.25	1.50	7.0	SNM.64..	2336-5014	2336-6014	S1904B	LYM10X12	DLM-2		

因為專業  
所以現代  
因為悠久  
所以厚重

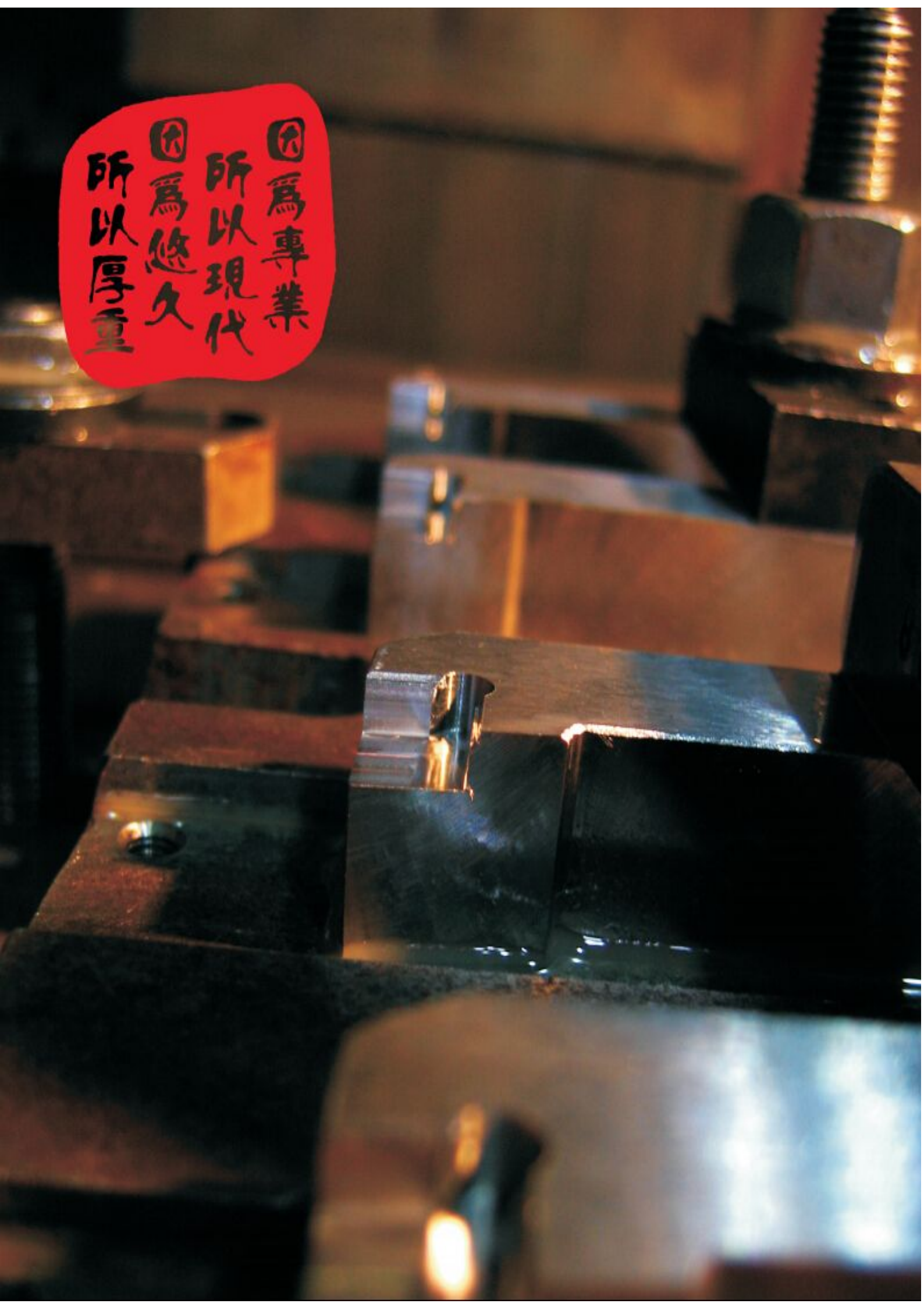





# Cutoutil

Metal Carbide Inserts, Turning Tools, Indexable Milling, Carbide Drill

www.cutoutil.com

## 90° 偏头端面车刀



TNMM, TNMA, TNMG

**DTFNR/L 端面加工**

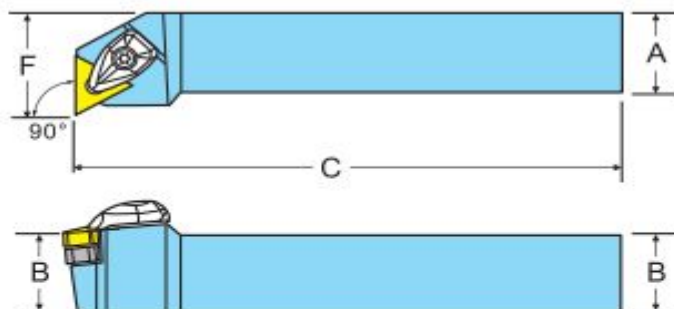

型号	刀体几何尺寸				适用刀片	产品货号		刀垫	刀垫螺钉	压板	压板螺丝	扳手、卡圈
	A	B	F	C		右刀	左刀					
DTFNR/L 2020K16	20	20	25	125	TNM.1604..	2340-0012	2340-1012	T1603B	LTM5x8	DLM-3	LE-05	S3 E3.5
DTFNR/L 2525M16	25	25	32	150	TNM.1604..	2340-0014	2340-1014					
DTFNR/L 2525M22	25	25	32	150	TNM.2204..	2340-0016	2340-1016					
DTFNR/L 3225P22	25	32	32	170	TNM.2204..	2340-0018	2340-1018	T2203B	LYM6x10	DLM-4	LE-06	S4 E4
DTFNR/L 3232P22	32	32	40	170	TNM.2204..	2340-0020	2340-1020					

## 英制

MODEL	DIMENSIONS				FOR INSERT	ITEM NO.		SHIM	SHIM SCREW	CLAMP	CLAMP SCREW	HEXKEY CLIPS
	A	B	F	C		RIGHT	LEFT					
DTFNR/L 12-3C	0.75	0.75	1.00	5.0	TNM.32..	2340-5012	2340-6012	T1603B	LTM5X8	DLM-3	LE-05	S3 E3.5
DTFNR/L 16-3D	1.00	1.00	1.25	6.0	TNM.32..	2340-5013	2340-6013					
DTFNR/L 16-4D	1.00	1.00	1.25	6.0	TNM.43..	2340-5014	2340-6014					
DTFNR/L 85-4E	1.00	1.25	1.25	7.0	TNM.43..	2340-5016	2340-6016	T2203B	LYM6X10	DLM-4	LE-06	S4 E4





# Cutoutil

Metal Carbide Inserts, Turning Tools, Indexable Milling, Carbide Drill

www.cutoutil.com

## 90° 偏头外圆车刀



TNMM, TNMA, TNMG

## DTGNR/L 外圆加工

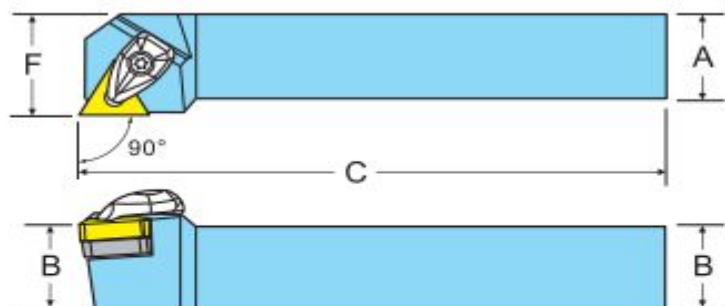

型号	刀体几何尺寸				适用刀片	产品货号		刀垫	刀垫螺钉	压板	压板螺丝	扳手, 卡圈
	A	B	F	C		右刀	左刀					
DTGNR/L 2020K16	20	20	25	125	TNM.1604..	2341-0012	2341-1012	T1603B	LTM5X8	DLM-3	LE-05	S3 E3.5
DTGNR/L 2520M16	20	25	32	150	TNM.1604..	2341-0013	2341-1013					
DTGNR/L 2525M16	25	25	32	150	TNM.1604..	2341-0014	2341-1014					
DTGNR/L 3225P16	25	32	32	170	TNM.1604..	2341-0016	2341-1016					
DTGNR/L 2525M22	25	25	32	150	TNM.2204..	2341-0018	2341-1018	T2203B	LYM8X10	DLM-4	LE-06	S4 E4
DTGNR/L 3225P22	25	32	32	170	TNM.2204..	2341-0020	2341-1020					
DTGNR/L 3232P22	32	32	40	170	TNM.2204..	2341-0022	2341-1022					

## 英制

MODEL	DIMENSIONS				FOR INSERT	ITEM NO.		SHIM	SHIM SCREW	CLAMP	CLAMP SCREW	HEXKEY CLIPS
	A	B	F	C		RIGHT	LEFT					
DTGNR/L 12-3C	0.75	0.75	1.00	5.0	TNM.32..	2341-5012	2341-6012	T1603B	LTM5X8	DLM-3	LE-05	S3 E3.5
DTGNR/L 16-3D	1.00	1.00	1.25	6.0	TNM.32..	2341-5013	2341-6013					
DTGNR/L 16-4D	1.00	1.00	1.25	6.0	TNM.43..	2341-5014	2341-6014	T2203B	LYM6X10	DLM-4	LE-06	S4 E4
DTGNR/L 20-4E	1.25	1.25	1.50	7.0	TNM.43..	2341-5016	2341-6016					



# Cutoutil

Metal Carbide Inserts, Turning Tools, Indexable Milling, Carbide Drill

www.cutoutil.com

## 60° 偏头外圆车刀



TNMM, TNMA, TNMG

## DTTNR/L 外圆加工

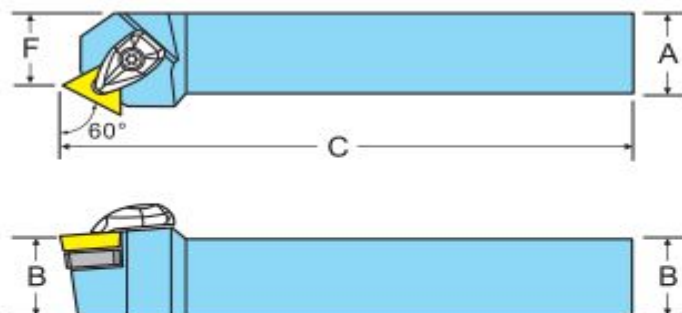

型号	刀体几何尺寸				适用刀片	产品货号		刀垫	刀垫螺钉	压板	压板螺丝	扳手、卡圈
	A	B	F	C		右刀	左刀					
DTTNR/L 2020K16	20	20	17	125	TNM.1604..	2343-0012	2343-1012	T1603B	LTM5X8	DLM-3	LE-05	S3 E3.5
DTTNR/L 2520M16	20	25	17	150	TNM.1604..	2343-0013	2343-1013	T1603B	LTM5X8	DLM-3	LE-05	S3 E3.5
DTTNR/L 2525M16	25	25	22	150	TNM.1604..	2343-0018	2343-1018	T1603B	LTM5X8	DLM-3	LE-05	S3 E3.5
DTTNR/L 2525M22	25	25	22	150	TNM.2204..	2343-0014	2343-1014	T2203B	LYM6X10	DLM-4	LE-06	S4 E4
DTTNR/L 3225P22	25	32	22	170	TNM.2204..	2343-0016	2343-1016	T2203B	LYM6X10	DLM-4	LE-06	S4 E4

## 英制

MODEL	DIMENSIONS				FOR INSERT	ITEM NO.		SHIM	SHIM SCREW	CLAMP	CLAMP SCREW	HEXKEY CLIPS
	A	B	F	C		RIGHT	LEFT					
DTTNR/L 12-3C	.75	.75	.63	5.0	TNM.32..	2343-5012	2343-6012	T1603B	LTM5X8	DLM-3	LE-05	S3,E3.5
DTTNR/L 16-3D	1.00	1.00	.88	6.0	TNM.32..	2343-5013	2343-6013	T1603B	LTM5X8	DLM-3	LE-05	S3,E3.5
DTTNR/L 16-4D	1.00	1.00	.88	6.0	TNM.43..	2343-5014	2343-6014	T2203B	LYM6X10	DLM-4	LE-06	S4 E4



# Cutoutil

Metal Carbide Inserts, Turning Tools, Indexable Milling, Carbide Drill

www.cutoutil.com

## 93° 偏头外圆车刀



TNMM, TNMA, TNMG

DTJNR/L 外圆加工

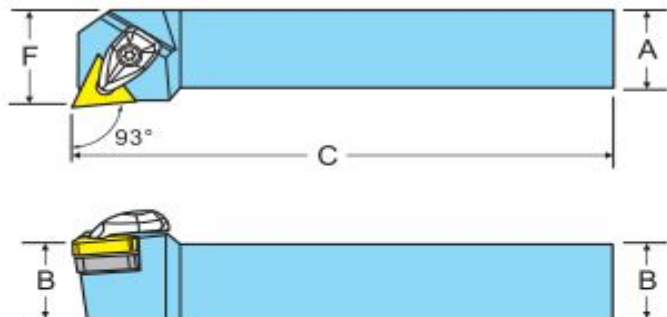

型号	刀体几何尺寸				适用刀片	产品货号		刀垫	刀垫螺钉	压板	压板螺丝	扳手, 卡圈
	A	B	F	C		右刀	左刀					
DTJNR/L 2020K16	20	20	25	125	TNM.1604..	2342-0012	2342-1012	T1603B	LTM5X8	DLM-3	LE-05	S3 E3.5
DTJNR/L 2525M16	25	25	32	150	TNM.1604..	2342-0014	2342-1014	T2203B	LYM6X10	DLM-4	LE-06	S4 E4
DTJNR/L 2525M22	25	25	32	150	TNM.2204..	2342-0016	2342-1016					
DTJNR/L 3232P22	32	32	40	170	TNM.2204..	2342-0018	2342-1018					

## 英制

MODEL	DIMENSIONS FOR INSERT				ITEM NO.	SHIM	SHIM SCREW	CLAMP	CLAMP SCREW	HEXKEY CLIPS		
	A	B	F	C							RIGHT	LEFT
DTJNR/L 12-3C	0.75	0.75	1.00	5.0	TNM.32..	2342-5012	2342-6012	T1603B	LTM5X8	DLM-3	LE-05	S3 E3.5
DTJNR/L 16-3D	1.00	1.00	1.25	6.0	TNM.32..	2342-5014	2342-6014	T2203B	LYM6X10	DLM-4	LE-06	S4 E4
DTJNR/L 16-4D	1.00	1.00	1.25	6.0	TNM.43..	2342-5016	2342-6016					
DTJNR/L 20-4E	1.25	1.25	1.50	7.0	TNM.43..	2342-5018	2342-6018					





# Cutoutil

Metal Carbide Inserts, Turning Tools, Indexable Milling, Carbide Drill

www.cutoutil.com

## 95° 偏头外圆端面车刀



WNMG, WTNM

**DWLNR/L 外圆，端面加工**

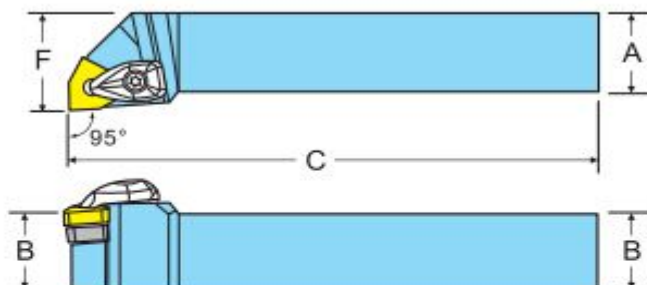

型号	刀体几何尺寸				适用刀片	产品货号		刀垫	刀垫螺钉	压板	压板螺丝	扳手、卡圈
	A	B	F	C		右刀	左刀					
DWLNR/L 2020K06	20	20	25	125	WNM.0604..	2345-0010	2345-1010					
DWLNR/L 2525M06	25	25	32	150	WNM.0804..	2345-0012	2345-1012	W0603B	LTM5X8	DLM-3	LE-05	S3 E4
DWLNR/L 3225P06	25	32	32	170	WNM.0606..	2345-0014	2345-1014					
DWLNR/L 2020K08	20	20	25	125	WNM.0804..	2345-0016	2345-1016					
DWLNR/L 2525M08	25	25	32	150	WNM.0804..	2345-0018	2345-1018	W0803B	LYM6X8			S4 E4
DWLNR/L 3225P08	25	32	32	170	WNM.0804..	2345-0020	2345-1020			DLM-4	LE-06	
DWLNR/L 3232R10	32	32	40	200	WNM.1006..	2345-0022	2345-1022	W1004B	LYM8X10			

## 英制

MODEL	DIMENSIONS				FOR INSERT	ITEM NO.		SHIM	SHIM SCREW	CLAMP	CLAMP SCREW	HEXKEY CLIPS
	A	B	F	C		RIGHT	LEFT					
DWLNR/L 12-4C	0.75	0.75	1.00	5.0	WNM.432.	2345-5010	2345-6010					
DWLNR/L 16-4D	1.00	1.00	1.25	6.0	WNM.432.	2345-5012	2345-6012	W0803B	LYM6X10			S4 E4
DWLNR/L 20-4E	1.25	1.25	1.50	7.0	WNM.432.	2345-5014	2345-6014			DLM-4	LE-06	
DWLNR/L 20-5E	1.25	1.25	1.50	7.0	WNM.542..	2345-5016	2345-6016	W1004B	LYM8X10			



# Cutoutil

Metal Carbide Inserts, Turning Tools, Indexable Milling, Carbide Drill

www.cutoutil.com

## 90° 偏头外圆车刀



WNMG, WTNM

DWGNR/L 外圆加工

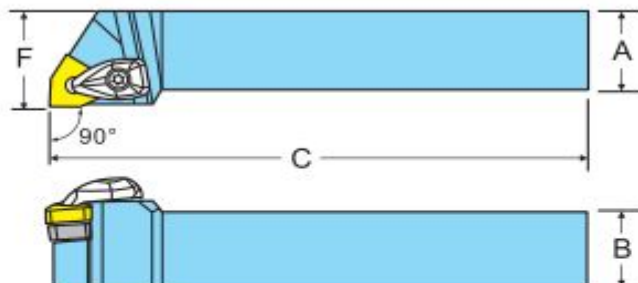

型号	刀体几何尺寸				通用刀片	产品货号		刀垫	刀垫螺钉	压板	压板螺丝	扳手·卡圈
	A	B	F	C		右刀	左刀					
DWGNR/L 2020K08	20	20	25	125	WNM.0804..	2346-0012	2346-1012	W0803B	LYM6X10	DLM-4	LE-06	S4 E4
DWGNR/L 2520M08	20	25	25	150	WNM.0804..	2346-0014	2346-1014					
DWGNR/L 2525M08	25	25	32	150	WNM.0806..	2346-0016	2346-1016	W1004B	LYM8X10	DLM-4	LE-06	S4 E4
DWGNR/L 2525M10	25	25	32	150	WNM.1006..	2346-0018	2346-1018					
DWGNR/L 3225P10	25	32	32	170	WNM.1006..	2346-0020	2346-1020					

## 英制

MODEL	DIMENSIONS				FOR INSERT	ITEM NO.		SHIM	SHIM SCREW	CLAMP	CLAMP SCREW	HEXKEY CLIPS
	A	B	F	C		RIGHT	LEFT					
DWGNR/L 12-4C	0.75	0.75	1.00	5.0	WNM.432	2346-5012	2346-6012	W0803B	LYM6X10	DLM-4	LE-06	S4 E4
DWGNR/L 16-4D	1.00	1.00	1.25	6.0	WNM.432	2346-5014	2346-6014					
DWGNR/L 16-5D	1.00	1.00	1.25	6.0	WNM.542	2346-5016	2346-6016	W1004B	LYM8X10	DLM-4	LE-06	S4 E4
DWGNR/L 85-5E	1.00	1.25	1.25	7.0	WNM.542	2346-5018	2346-6018					



# Cutoutil

Metal Carbide Inserts, Turning Tools, Indexable Milling, Carbide Drill

www.cutoutil.com

## 75°直头外圆车刀



CNMG, CNMA, CNMM

DCBNR/L 外圆加工

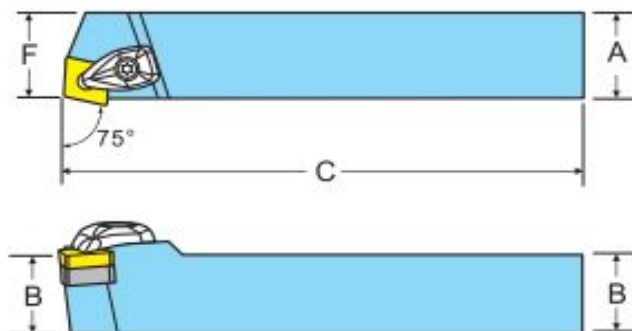

型号	刀体几何尺寸				通用刀片	产品货号		刀垫	刀垫螺钉	压板	压板螺丝	扳手、卡圈
	A	B	F	C		右刀	左刀					
DCBNR/L 2020K12	20	20	17	125	CNMG1204	2347-0008	2347-1008	C1203B	LYM6X10			
DCBNR/L 2525M12	25	25	22	150	CNMG1204	2347-0010	2347-1010					
DCBNR/L 2525M16	25	25	22	150	CNMG1606	2347-0012	2347-1012			DLM-4		
DCBNR/L 3225P16	25	32	22	170	CNMG1606	2347-0014	2347-1014	C1604B	LYM8X10		LE-06	S4 E4
DCBNR/L 3232P16	32	32	27	170	CNMG1606	2347-0016	2347-1016					
DCBNR/L 3232P19	32	32	27	170	CNMG1906	2347-0018	2347-1018					
DCBNR/L 4040R19	40	40	35	200	CNMG1906	2347-0020	2347-1020	C1904B	LYM10X12	DLM-2		

## 英制

MODEL	DIMENSIONS				FOR INSERT	ITEM NO.		SHIM	SHIM SCREW	CLAMP	CLAMP SCREW	HEXKEY CLIPS
	A	B	F	C		RIGHT	LEFT					
DCBNR/L 12-4C	0.75	0.75	.63	5.0	CN.432	2347-5008	2347-6008	C1203B	LYM6X10			
DCBNR/L 16-4D	1.00	1.00	.88	6.0	CN.432	2347-5010	2347-6010					
DCBNR/L 16-5D	1.00	1.00	.88	6.0	CN.542	2347-5012	2347-6012			DLM-4	LE-06	S4 E4
DCBNR/L 85-5E	1.00	1.25	.88	7.0	CN.542	2347-5014	2347-6014	C1604B	LYM8X10			
DCBNR/L 20-5E	1.25	1.25	1.05	7.0	CN.542	2347-5016	2347-6016					





# Cutoutil

Metal Carbide Inserts, Turning Tools, Indexable Milling, Carbide Drill

www.cutoutil.com

## 45°直头外圆车刀



**DSDNN** 外圆加工

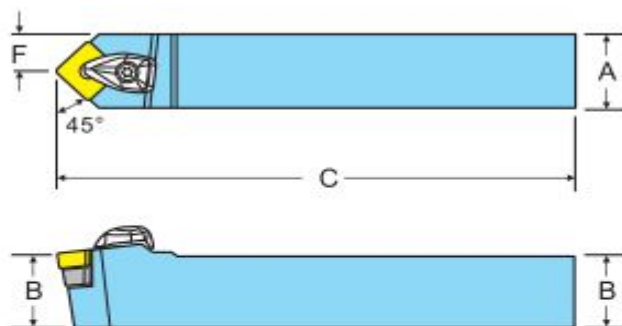

型号	刀体几何尺寸				适用刀片	产品货号						
	A	B	F	C			刀垫	刀垫螺钉	压板	压板螺丝	扳手, 卡圈	
DSDNN 2020K12	20	20	10	125	SNM.1204..	2333-0012	S1203B	LYM6X10				
DSDNN 2525M12	25	25	12.5	150	SNM.1204..	2333-0014			DLM-4			
DSDNN 2525M15	25	25	12.5	150	SNM.1506..	2333-0024				LE-06		
DSDNN 3225P15	25	32	12.5	170	SNM.1506..	2333-0026	S1504B	LYM8X10			S4 E4	
DSDNN 3232P15	32	32	16	170	SNM.1506..	2333-0028						
DSDNN 3232P19	32	32	16	170	SNM.1906..	2333-0020	S1904B	LYM10X12	DLM-2			
DSDNN 4040R19	40	40	20	200	SNM.1906..	2333-0022						

## 英制

MODEL	DIMENSIONS				FOR INSERT	ITEM NO.						
	A	B	F	C			SHIM	SHIM SCREW	CLAMP	CLAMP SCREW	HEXKEY CLIPS	
DSDNN 12-4C	0.75	0.75	.375	5.0	SNM.432	2333-5012						
DSDNN 16-4D	1.00	1.00	.50	6.0	SNM.432	2333-5014	S1203B	LYM6X10				
DSDNN 85-4E	1.00	1.25	.50	7.0	SNM.432	2333-5015			DLM-4			
DSDNN 16-5D	1.00	1.00	.50	6.0	SNM.542	2333-5016				LE-06		
DSDNN 85-5E	1.00	1.25	.50	7.0	SNM.542	2333-5017	S1504B	LYM8X10			S4 E4	
DSDNN 20-5E	1.25	1.25	.625	7.0	SNM.542	2333-5020						
DSDNN 20-6E	1.25	1.25	.625	7.0	SNM.643	2333-5018	S1904B	LYM10X12	DLM-2			



# Cutoutil

Metal Carbide Inserts, Turning Tools, Indexable Milling, Carbide Drill

www.cutoutil.com

## 75° 偏头端面车刀

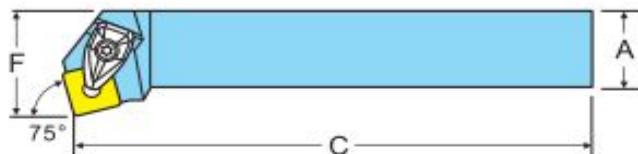

## DSKNR/L 端面加工

型号	刀体几何尺寸				适用刀片	产品货号		刀垫	刀垫螺钉	压板	压板螺丝	扳手·卡圈
	A	B	F	C		右刀	左刀					
DSKNR/L 2020K12	20	20	25	125	SNM.1204	2334-0012	2334-1012	S1203B	LYM6X10			
DSKNR/L 2525M12	25	25	32	150	SNM.1204	2334-0014	2334-1014					
DSKNR/L 2525M15	25	25	32	150	SNM.1606	2334-0016	2334-1016			DLM-4		
DSKNR/L 3225P15	25	32	32	170	SNM.1606	2334-0018	2334-1018	S1504B	LYM8X10		LE-06	S4 E4
DSKNR/L 3232P15	32	32	40	170	SNM.1606	2334-0020	2334-1020					
DSKNR/L 4040R19	40	40	50	200	SNM.1906	2334-0022	2334-1022	S1904B	LYM10X12	DLM-2		

## 英制

MODEL	DIMENSIONS				FOR INSERT	ITEM NO.		SHIM	SHIM SCREW	CLAMP	CLAMP SCREW	HEXKEY CLIPS
	A	B	F	C		RIGHT	LEFT					
DSKNR/L 12-4C	0.75	0.75	1.00	4.5	CN.432	2334-5010	2334-6010	S1203B	LYM6X10			
DSKNR/L 16-4D	1.00	1.00	1.25	6.0	CN.432	2334-5012	2334-6012					
DSKNR/L 16-5D	1.00	1.00	1.25	6.0	CN.542	2334-5014	2334-6014			DLM-4	LE-06	S4 E4
DSKNR/L 85-5E	1.00	1.25	1.25	7.0	CN.542	2334-5016	2334-6016	S1504B	LYM8X10			
DSKNR/L 20-5E	1.25	1.25	1.50	7.0	CN.542	2334-5018	2334-6018					

## 车刀术语



### 后角 (Relief angle)

后角的设计是为了避免被加工件和刀片之间的摩擦

相同切削用量的情况下

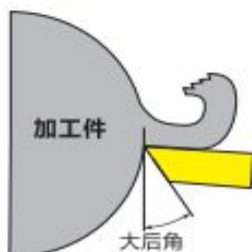
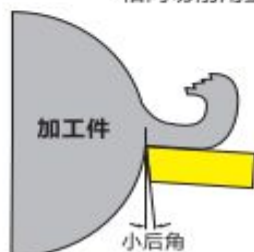

后角面的磨损 (mm)

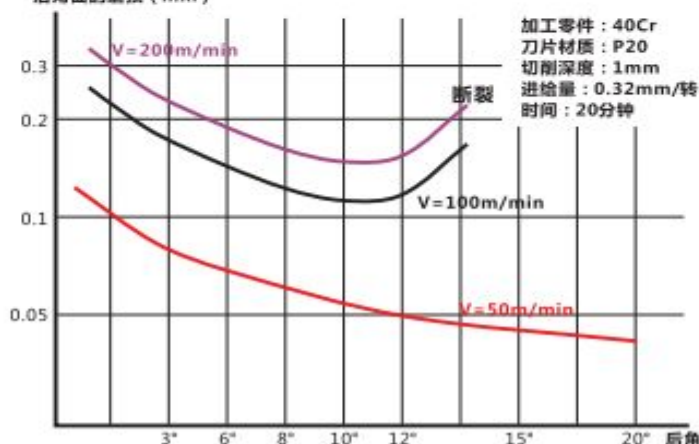



# Cutoutil

Metal Carbide Inserts, Turning Tools, Indexable Milling, Carbide Drill

www.cutoutil.com

## 75°偏头外圆车刀



## DSRNR/L 外圆加工

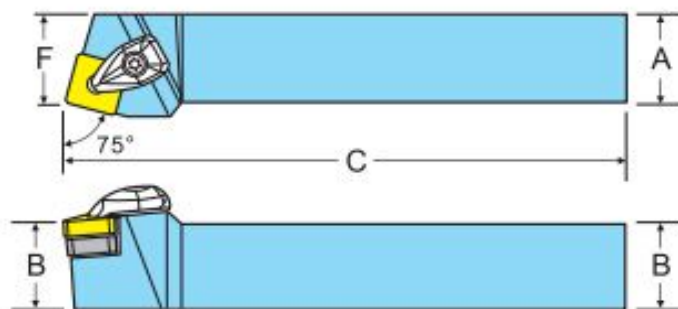

型号	刀体几何尺寸				适用刀片	产品货号		刀垫	刀垫螺钉	压板	压板螺丝	扳手·卡圈
	A	B	F	C		右刀	左刀					
DSRNR/L2020K12	20	20	22	125	SNM.1204..	2335-0010	2335-1010	S1203B	LYM6X10			
DSRNR/L 2525M12	25	25	27	150	SNM.1204..	2335-0012	2335-1012					
DSRNR/L 2525M15	25	25	27	150	SNM.1506..	2335-0014	2335-1014			DLM-4	LE-06	S4 E4
DSRNR/L 3225P15	25	32	27	170	SNM.1506..	2335-0016	2335-1016	S1504B	LYM8X10			
DSRNR/L 3232P15	32	32	27	170	SNM.1506..	2335-0018	2335-1018					
DSRNR/L 4040R19	40	40	43	200	SNM.1906..	2335-0020	2335-1020	S1904B	LYM10X12	DLM-2		

## 英制

MODEL	DIMENSIONS				FOR INSERT	ITEM NO.		SHIM	SHIM SCREW	CLAMP	CLAMP SCREW	HEXKEY CLIPS
	A	B	F	C		RIGHT	LEFT					
DSRNR/L 12-4B	0.75	0.75	.88	4.5	SNM.432	2335-5012	2335-6012	S1203B	LYM6X10			
DSRNR/L 16-4D	1.00	1.00	1.13	6.0	SNM.432	2335-5014	2335-6014			DLM-4	LE-06	S4 E4
DSRNR/L 16-5D	1.00	1.25	1.13	6.0	SNM.542	2335-5016	2335-6016	S1504B	LYM8X10			
DSRNR/L 20-5E	1.00	1.00	1.35	7.0	SNM.542	2335-5018	2335-6018					
DSRNR/L 20-6E	1.00	1.25	1.35	7.0	SNM.643	2335-5020	2335-6020	S1904B	LYM10X12	DLM-2		





# Cutoutil

Metal Carbide Inserts, Turning Tools, Indexable Milling, Carbide Drill

www.cutoutil.com

## 63°直头外圆仿形车刀



DNMG, DNMA

**PDNNR/L 外圆·仿形加工**



型号	刀体几何尺寸				通用刀片	产品货号		刀垫	弹簧套	杠杆	杠杆螺丝	扳手
	A	B	F	C		右刀	左刀					
PDNNR/L 2525M15	25	25	12.5	150	DN..1506.	2368-0010	2368-1010	D15A	GH0607	G0517-W	GL0826	S4
PDNNR/L 3225P15	25	32	12.5	170	DN..1506.	2368-0012	2368-1012					
PDNNR/L 3232P15	32	32	16	170	DN..1506.	2368-0014	2368-1014					
PDNNR/L 4025R15	25	40	12.5	200	DN..1506.	2368-0016	2368-1016					

## 英制

MODEL	DIMENSIONS				FOR INSERT	ITEM NO.		SHIM	SHIM PIN	CLAMP	CLAMP SCREW	HEXKEY
	A	B	F	C		RIGHT	LEFT					
PDNNR/L 16-4D	1.00	1.00	.50	6.0	DN..432	2368-5010	2368-6010	D15A	GH0607	G0517-W	GL0826	S4
PDNNR/L 85-4E	1.00	1.25	.50	7.0	DN..432	2368-5012	2368-6012					
PDNNR/L 20-4E	1.25	1.25	.625	7.0	DN..432	2368-5014	2368-6014					
PDNNR/L 86-4F	1.00	1.50	.50	8.0	DN..432	2368-5016	2368-6016					



# Cutoutil

Metal Carbide Inserts, Turning Tools, Indexable Milling, Carbide Drill

www.cutoutil.com

## 75°直头外圆车刀



CNMM, CNMG, CNMA

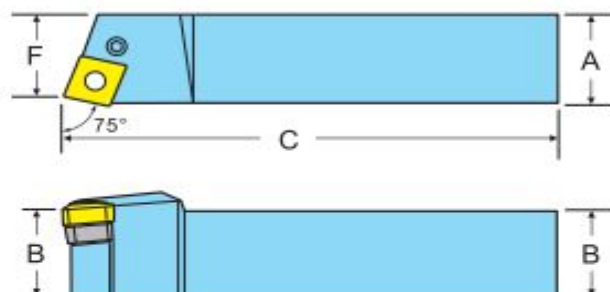

## PCBNR/L 外圆加工

型号	刀体几何尺寸				适用刀片	产品货号		刀垫	弹簧套	杠杆	杠杆螺丝	扳手
	A	B	F	C		右刀	左刀					
PCBNR/L 2020K12	20	20	17	125	CN..1204.	2350-0012	2350-1012					
PCBNR/L 2525M12	25	25	22	150	CN..1204.	2350-0014	2350-1014	C12A	GH0607	G0514-W	GL0822	
PCBNR/L 3232P12	32	32	27	170	CN..1204.	2350-0016	2350-1016					S4
PCBNR/L 2525M16	25	25	22	150	CN..1606.	2350-0018	2350-1018					
PCBNR/L 3225P16	25	32	22	170	CN..1606.	2350-0019	2350-1019	C16A	GH0709	G0616-W	GL0826	
PCBNR/L 3232P16	32	32	27	170	CN..1606.	2350-0020	2350-1020					
PCBNR/L 3232P19	32	32	27	170	CN..1906.	2350-0022	2350-1022	C19A	GH0811	G0719-W	GL1031	S5
PCBNR/L 4040R19	40	40	35	200	CN..1906.	2350-0024	2350-1024					

## 英制

MODEL	DIMENSIONS				FOR INSERT	ITEM NO.		SHIM	SHIM PIN	CLAMP	CLAMP SCREW	HEXKEY
	A	B	F	C		RIGHT	LEFT					
PCBNR/L 12-4C	0.75	0.75	.63	5.0	CN..43.	2350-5012	2350-6012					
PCBNR/L 16-4D	1.00	1.00	.88	6.0	CN..43.	2350-5014	2350-6012	C12A	GH0607	G0514-W	GL0822	
PCBNR/L 16-5D	1.00	1.00	.88	6.0	CN..54.	2350-5018	2350-6018					S4
PCBNR/L 85-5E	1.00	1.25	.88	7.0	CN..54.	2350-5020	2350-6020	C16A	GH0709	G0616-W	GL0826	
PCBNR/L 20-6E	1.25	1.25	1.05	7.0	CN..64.	2350-5022	2350-6022					
PCBNR/L 24-6F	1.50	1.50	1.30	8.0	CN..64.	2350-5024	2350-6024	C19A	GH0811	G0719-W	GL1031	S5



# Cutoutil

Metal Carbide Inserts, Turning Tools, Indexable Milling, Carbide Drill

www.cutoutil.com

## 95° 偏头外圆端面车刀



CNMM, CNMG, CNMA

**PCLNR/L 外圆, 端面加工**

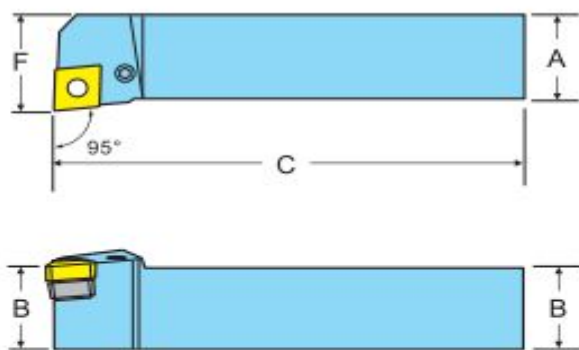

刀体几何尺寸					产品货号			    				
型号	A	B	F	C	通用刀片	右刀	左刀	刀垫	弹簧套	杠杆	杠杆螺丝	扳手
PCLNR/L 1616H09	16	16	20	100	CN..0903.	2351-0012	2351-1012	C09A	GH0405	G0312-W	GL0617A	S3
PCLNR/L 2020K09	20	20	25	125	CN..0903.	2351-0014	2351-1014					
PCLNR/L 2020K12	20	20	25	125	CN..1204.	2351-0018	2351-1018					
PCLNR/L 2525M12	25	25	32	150	CN..1204.	2351-0020	2351-1020	C12A	GH0607	G0514-W	GL0822	
PCLNR/L 3232P12	32	32	40	170	CN..1204.	2351-0022	2351-1022					S4
PCLNR/L 2525M16	25	25	32	150	CN..1606.	2351-0024	2351-1024					
PCLNR/L 3225P16	25	32	32	170	CN..1606.	2351-0025	2351-1025	C16A	GH0709	G0616-W	GL0826	
PCLNR/L 3232P16	32	32	40	170	CN..1606.	2351-0026	2351-1026					
PCLNR/L 3232P19	32	32	40	170	CN..1906.	2351-0028	2351-1028	C19A	GH0811	G0719-W	GL1031	S5
PCLNR/L 4040R19	40	40	50	200	CN..1906.	2351-0030	2351-1030					

英制

DIMENSIONS					ITEM NO.			    				
MODEL	A	B	F	C	FOR INSERT	RIGHT	LEFT	SHIM	SHIM PIN	CLAMP	CLAMP SCREW	HEXKEY
PCLNR/L 12-4B	0.75	0.75	1.00	4.5	CN..43.	2351-5010	2351-6010					
PCLNR/L 12-4C	0.75	0.75	1.00	5.0	CN..43.	2351-5012	2351-6012	C12A	GH0607	G0514-W	GL0822	
PCLNR/L 16-4D	1.00	1.00	1.25	6.0	CN..43.	2351-5015	2351-6015					S4
PCLNR/L 16-5D	1.00	1.00	1.25	6.0	CN..54.	2351-5018	2351-6018					
PCLNR/L 85-5E	1.00	1.25	1.25	7.0	CN..54.	2351-5020	2351-6020	C16A	GH0709	G0616-W	GL0826	
PCLNR/L 20-6E	1.25	1.25	1.50	7.0	CN..64.	2351-5022	2351-6022					
PCLNR/L 24-6F	1.50	1.50	2.00	8.0	CN..64.	2351-5024	2351-6024	C19A	GH0811	G0719-W	GL1031	S5





# Cutoutil

Metal Carbide Inserts, Turning Tools, Indexable Milling, Carbide Drill

www.cutoutil.com

## 90° 偏头外圆车刀



## PCGNR/L 外圆加工

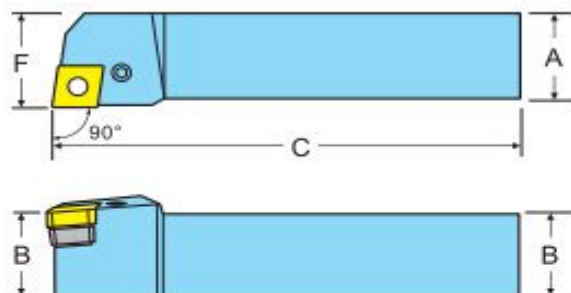

型号	刀体几何尺寸				适用刀片	产品货号		刀垫	弹簧套	杠杆	杠杆螺丝	扳手
	A	B	F	C		右刀	左刀					
PCGNR/L 2020K12	20	20	25	125	CN..1204.	2352-0012	2352-1012	C12A	GH0607	G0514-W	GL0822	S4
PCGNR/L 2525M12	25	25	32	150	CN..1204.	2352-0013	2352-1013					
PCGNR/L 2525M16	25	25	32	150	CN..1606.	2352-0014	2352-1014	C16A	GH0709	G0616-W	GL0826	S4
PCGNR/L 3225P16	25	32	32	170	CN..1606.	2352-0016	2352-1016					
PCGNR/L 3232P16	32	32	40	170	CN..1606.	2352-0017	2352-1017	C19A	GH0811	G0719-W	GL1031	S5
PCGNR/L 3232P19	32	32	40	170	CN..1906.	2352-0018	2352-1018					
PCGNR/L 4040R19	40	40	50	200	CN..1906.	2352-0020	2352-1020					

## 英制

MODEL	DIMENSIONS				FOR INSERT	ITEM NO.		SHIM	SHIM PIN	CLAMP	CLAMP SCREW	HEXKEY
	A	B	F	C		RIGHT	LEFT					
PCGNR/L 12-4B	0.75	0.75	1.00	4.5	CN..43.	2352-5010	2352-6010	C12A	GH0607	G0514-W	GL0822	S4
PCGNR/L 12-4C	0.75	0.75	1.00	5.0	CN..43.	2352-5012	2352-6012					
PCGNR/L 16-4D	1.00	1.00	1.25	5.0	CN..43.	2352-5013	2352-6013	C16A	GH0709	G0616-W	GL0826	S4
PCGNR/L 16-5D	1.00	1.00	1.25	6.0	CN..54.	2352-5018	2352-6018					
PCGNR/L 85-5E	1.00	1.25	1.25	7.0	CN..54.	2352-5020	2352-6020	C19A	GH0811	G0719-W	GL1031	S5
PCGNR/L 20-5E	1.25	1.25	1.50	7.0	CN..54.	2352-5022	2352-6022					
PCGNR/L 24-6F	1.50	1.50	2.00	8.0	CN..64.	2352-5024	2352-6024					



# Cutoutil

Metal Carbide Inserts, Turning Tools, Indexable Milling, Carbide Drill

www.cutoutil.com

## 90° 偏头端面车刀



CNMM, CNMG, CNMA

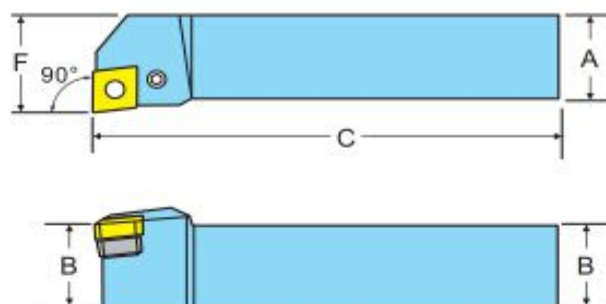

## PCFNR/L 端面加工

型号	刀体几何尺寸				适用刀片	产品货号		刀垫	弹簧套	缸杆	缸杆螺丝	扳手
	A	B	F	C		右刀	左刀					
PCFNR/L 2020K12	20	20	25	125	CN..1204.	2353-0012	2353-1012	C12A	GH0607	G0514-W	GL0822	S4
PCFNR/L 2525M12	25	25	32	150	CN..1204.	2353-0013	2353-1013					
PCFNR/L 2525M16	25	25	32	150	CN..1606.	2353-0014	2353-1014	C16A	GH0709	G0616-W	GL0826	
PCFNR/L 3225P16	25	32	32	170	CN..1606.	2353-0016	2353-1016					
PCFNR/L 3232P19	32	32	40	170	CN..1906.	2353-0018	2353-1018	C19A	GH0811	G0719-W	GL1031	
PCFNR/L 4040R19	40	40	50	200	CN..1906.	2353-0020	2353-1020					

## 英制

MODEL	DIMENSIONS				FOR INSERT	ITEM NO.		SHIM	SHIM PIN	CLAMP	CLAMP SCREW	HEXKEY
	A	B	F	C		RIGHT	LEFT					
PCFNR/L 12-4C	0.75	0.75	1.00	5.0	CN..43.	2353-5012	2353-6012	C12A	GH0607	G0514-W	LGL0822	S4
PCFNR/L 16-4D	1.00	1.00	1.25	6.0	CN..43.	2353-5013	2353-6013					
PCFNR/L 16-5D	1.00	1.00	1.25	6.0	CN..54.	2353-5014	2353-6014	C16A	GH0709	G0616-W	LGL0826	
PCFNR/L 85-5E	1.00	1.25	1.50	7.0	CN..54.	2353-5016	2353-6016					
PCFNR/L 20-5E	1.25	1.25	1.50	7.0	CN..54.	2353-5018	2353-6018	C19A	GH0811	G0719-W	LGL1031	
PCFNR/L 24-6F	1.50	1.50	2.00	8.0	CN..64.	2353-5020	2353-6020					



# Cutoutil

Metal Carbide Inserts, Turning Tools, Indexable Milling, Carbide Drill

www.cutoutil.com

## 75° 偏头端面车刀



CNMM, CNMG, CNMA

## PCKNR/L 端面加工

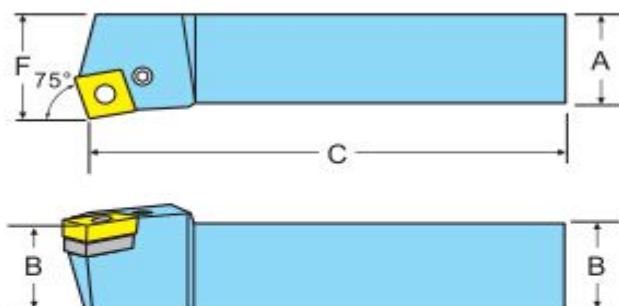

型号	刀体几何尺寸				适用刀片	产品货号		刀垫	弹簧套	杠杆	杠杆螺丝	扳手
	A	B	F	C		右刀	左刀					
PCKNR/L 2020K12	20	20	25	125	CN..1204.	2366-0012	2366-1012	C12A	GH0607	G0514-W	GL0822	S4
PCKNR/L 2525M12	25	25	32	150	CN..1204.	2366-0014	2366-1014	C16A	GH0709	G0616-W	GL0826	
PCKNR/L 2525M16	25	25	32	150	CN..1606.	2366-0016	2366-1016	C19A	GH0811	G0719-W	GL1031	
PCKNR/L 3225P16	25	32	32	170	CN..1606.	2366-0018	2366-1018					
PCKNR/L 3232P19	32	32	40	170	CN..1906.	2366-0020	2366-1020					

## 英制

MODEL	DIMENSIONS				FOR INSERT	ITEM NO.		SHIM	SHIM PIN	CLAMP	CLAMP SCREW	HEXKEY
	A	B	F	C		RIGHT	LEFT					
PCKNR/L 12-4C	0.75	0.75	1.00	5.0	CN..43.	2366-5012	2366-6012	C12A	GH0607	G0514-W	GL0822	S4
PCKNR/L 16-4D	1.00	1.00	1.25	6.0	CN..43.	2366-5014	2366-6014	C16A	GH0709	G0616-W	GL0826	
PCKNR/L 16-5D	1.00	1.00	1.25	6.0	CN..54.	2366-5016	2366-6016					
PCKNR/L 85-5E	1.00	1.25	1.25	7.0	CN..54.	2366-5018	2366-6018					
PCKNR/L 20-5E	1.25	1.25	1.50	7.0	CN..54.	2366-5020	2366-6020					





# Cutoutil

Metal Carbide Inserts, Turning Tools, Indexable Milling, Carbide Drill

www.cutoutil.com

## 93° 偏头外圆仿形车刀



DNMA, DNMG, DNMM

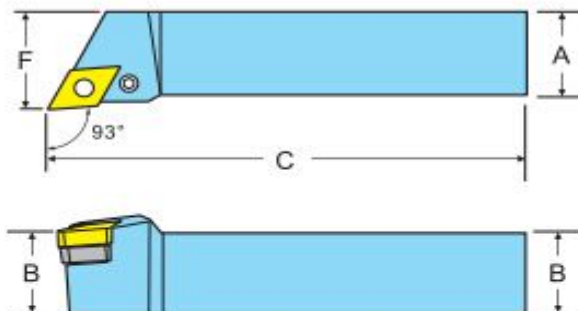

## PDJNR/L 外圆·仿形加工

型号	刀体几何尺寸				适用刀片	产品货号		刀垫	弹簧套	缸杆	缸杆螺丝	扳手
	A	B	F	C		右刀	左刀					
PDJNR/L 2020K11	20	20	25	125	DN..1104.	2354-0014	2354-1014	D11A	GH0405	G0315-W	GL0617A	S3
PDJNR/L 2525M11	25	25	32	150	DN..1104.	2354-0016	2354-1016					
PDJNR/L 2020K15	20	20	25	125	DN..1506.	2354-0018	2354-1018					
PDJNR/L 2525M15	25	25	32	150	DN..1506.	2354-0020	2354-1020					
PDJNR/L 3225P15	25	32	32	170	DN..1506.	2354-0021	2354-1021	D15A	GH0607	G0517-W	GL0826	S4
PDJNR/L 3232P15	32	32	40	170	DN..1506.	2354-0022	2354-1022					
PDJNR/L 4025R15	25	40	32	200	DN..1506.	2354-0024	2354-1024					

## 英制

MODEL	DIMENSIONS				FOR INSERT	ITEM NO.		SHIM	SHIM PIN	CLAMP	CLAMP SCREW	HEXKEY
	A	B	F	C		RIGHT	LEFT					
PDJNR/L 12-4C	0.75	0.75	1.00	5.0	DN..44.	2354-5010	2354-6010					
PDJNR/L 16-4D	1.00	1.00	1.25	6.0	DN..44.	2354-5012	2354-6012					
PDJNR/L 85-4E	1.00	1.25	1.25	7.0	DN..44.	2354-5014	2354-6014	D15A	GH0607	G0517-W	GL0826	S4
PDJNR/L 20-4E	1.25	1.25	1.50	7.0	DN..44.	2354-5016	2354-6016					
PDJNR/L 86-4F	1.00	1.50	1.25	8.0	DN..44.	2354-5018	2354-6018					



# Cutoutil

Metal Carbide Inserts, Turning Tools, Indexable Milling, Carbide Drill

www.cutoutil.com

## 107.5°偏头外圆仿形车刀



DNMA, DNMG, DNMM

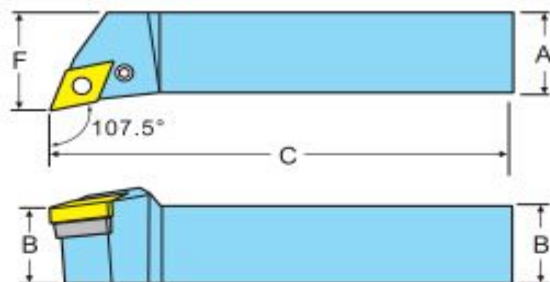

## PDQNR/L 外圆，仿形加工

型号	刀体几何尺寸				适用刀片	产品货号		刀垫	弹簧套	杠杆	杠杆螺丝	扳手
	A	B	F	C		右刀	左刀					
PDQNR/L 2525M15	25	25	32	150	DN..1506.	2355-0012	2355-1012	D15A	GH0607	G0517-W	GL0826	S4
PDQNR/L 3225P15	25	32	32	170	DN..1506.	2355-0014	2355-1014					
PDQNR/L 3232P15	32	32	40	170	DN..1506.	2355-0016	2355-1016					
PDQNR/L 4025R15	25	40	32	200	DN..1506.	2355-0018	2355-1018					

## 英制

MODEL	DIMENSIONS				FOR INSERT	ITEM NO.		SHIM	SHIM PIN	CLAMP	CLAMP SCREW	HEXKEY
	A	B	F	C		RIGHT	LEFT					
PDQNR/L 16-4D	1.00	1.00	1.25	6.0	DN..44.	2355-5012	2355-6012	D15A	GH0607	G0517-W	GL0826	S4
PDQNR/L 85-4E	1.00	1.25	1.25	7.0	DN..44.	2355-5014	2355-6014					
PDQNR/L 20-4E	1.25	1.25	1.50	7.0	DN..44.	2355-5016	2355-6016					
PDQNR/L 86-4F	1.00	1.50	1.25	8.0	DN..44.	2355-5018	2355-6018					



# Cutoutil

Metal Carbide Inserts, Turning Tools, Indexable Milling, Carbide Drill

www.cutoutil.com

## 62.5°直头外圆仿形车刀



DNMA,DNMG,DNMM

## PDPNN 外圆·仿形加工

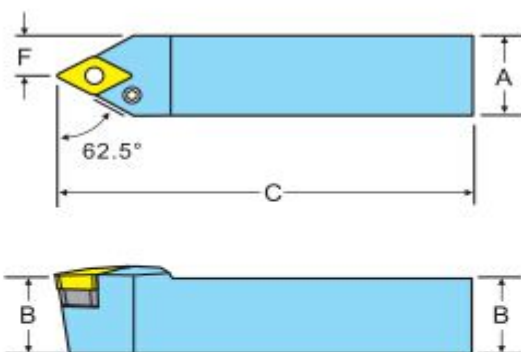

型号	刀体几何尺寸				通用刀片	产品货号					
	A	B	F	C			刀垫	弹簧套	杠杆	杠杆螺丝	扳手
PDPNN 2525M15	25	25	12.5	150	DN..1506.	2357-0012	D15A	GH0607	G0517-W	GL0826	S4
PDPNN 3225P15	25	32	12.5	170	DN..1506.	2357-0014					
PDPNN 3232P15	32	32	16	170	DN..1506.	2357-0016					
PDPNN 4025R15	25	40	12.5	200	DN..1506.	2357-0018					

## 英制

MODEL	DIMENSIONS				FOR INSERT	ITEM NO.					
	A	B	F	C			SHIM	SHIM PIN	CLAMP	CLAMP SCREW	HEXKEY
PDPNN 12-4C	0.75	0.75	.375	5.0	DN..44.	2357-5010	D15A	GH0607	G0517-W	GL0826	S4
PDPNN 16-4D	1.00	1.00	.50	6.0	DN..44.	2357-5012					
PDPNN 85-4E	1.00	1.25	.50	7.0	DN..44.	2357-5014					
PDPNN 20-4E	1.25	1.25	.625	7.0	DN..44.	2357-5016					
PDPNN 86-4F	1.00	1.50	.5	8.0	DN..44.	2357-5018					





# Cutoutil

Metal Carbide Inserts, Turning Tools, Indexable Milling, Carbide Drill

www.cutoutil.com

## 75°直头外圆仿形车刀



SNMG, SNMA, SNMM

## PSBNR/L 外圆加工

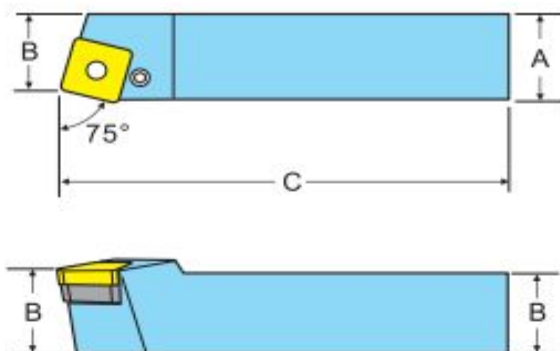

型号	刀体几何尺寸				适用刀片	产品货号		刀垫	弹簧套	缸杆	缸杆螺丝	扳手
	A	B	F	C		右刀	左刀					
PSBNR/L 1616H09	16	16	13	100	SN..0903.	2358-0012	2358-1012	S09A	GH0405	G0312-W	GL0617A	S3
PSBNR/L 2020K09	20	20	17	125	SN..0903.	2358-0014	2358-1014					
PSBNR/L 2020K12	20	20	17	125	SN..1204.	2358-0016	2358-1016					
PSBNR/L 2525M12	25	25	22	150	SN..1204.	2358-0018	2358-1018	S12A	GH0607	G0514-W	GL0822	
PSBNR/L 3225P12	25	32	22	170	SN..1204.	2358-0020	2358-1020					S4
PSBNR/L 3232P12	32	32	27	170	SN..1204.	2358-0022	2358-1022					
PSBNR/L 2525M15	25	25	22	150	SN..1506.	2358-0024	2358-1024	S15A	GH0709	G0616-W	GL0826	
PSBNR/L 3232P15	32	32	27	170	SN..1506.	2358-0026	2358-1026					
PSBNR/L 3232P19	32	32	27	170	SN..1906.	2358-0028	2358-1028	S19A	GH0811	G0719-W	GL1031	S5
PSBNR/L 4040R19	40	40	35	200	SN..1906.	2358-0030	2358-1030					

## 英制

MODEL	DIMENSIONS				FOR INSERT	ITEM NO.		SHIM	SHIM PIN	CLAMP	CLAMP SCREW	HEXKEY
	A	B	F	C		RIGHT	LEFT					
PSBNR/L 12-4C	0.75	0.75	.63	5.00	SN..43.	2358-5012	2358-6012					
PSBNR/L 64-4D	0.75	1.00	.63	6.00	SN..43.	2358-5014	2358-6014	S12A	GH0607	G0514-W	GL0822	
PSBNR/L 16-4D	1.00	1.00	.88	6.00	SN..43.	2358-5015	2358-6015					S4
PSBNR/L 16-5D	1.00	1.00	.88	6.00	SN..54.	2358-5016	2358-6016					
PSBNR/L 85-5E	1.00	1.25	.88	7.00	SN..54.	2358-5018	2358-6018	S15A	GH0709	G0616-W	GL0826	
PSBNR/L 20-5E	1.25	1.25	1.05	7.00	SN..54.	2358-5019	2358-6019					
PSBNR/L 20-6E	1.25	1.25	1.05	7.00	SN..64.	2358-5020	2358-6020					
PSBNR/L 24-6F	1.50	1.50	1.30	8.00	SN..64.	2358-5022	2358-6022	S19A	GH0811	G0719-W	GL1031	S5



# Cutoutil

Metal Carbide Inserts, Turning Tools, Indexable Milling, Carbide Drill

www.cutoutil.com

## 75° 偏头端面车刀



SNMG, SNMA, SNMM

## PSKNR/L 端面加工

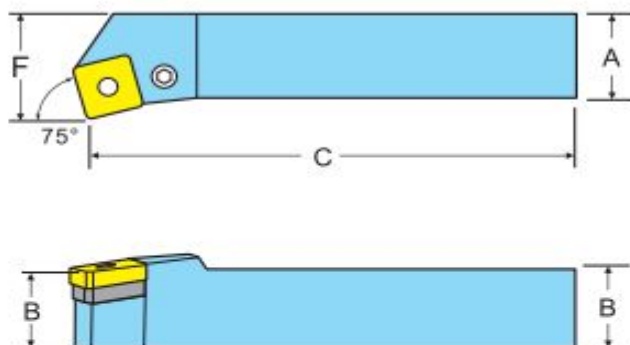

型号	刀体几何尺寸				适用刀片	产品货号		刀垫	弹簧套	杠杆	杠杆螺丝	扳手
	A	B	F	C		右刀	左刀					
PSKNR/L 2020K12	20	20	25	125	SN..1204.	2359-0016	2359-1016					
PSKNR/L 2525M12	25	25	32	150	SN..1204.	2359-0018	2359-1018	S12A	GH0607	G0514-W	GL0822	
PSKNR/L 3232P12	32	32	40	170	SN..1204.	2359-0020	2359-1020					S4
PSKNR/L 2525M15	25	25	32	150	SN..1504.	2359-0022	2359-1022	S15A	GH0709	G0616-W	GL0826	
PSKNR/L 3232P15	32	32	40	170	SN..1506.	2359-0024	2359-1024					
PSKNR/L 3232P19	32	32	40	170	SN..1906.	2359-0026	2359-1026	S19A	GH0811	G0719-W	GL1031	S5
PSKNR/L 4040R19	40	40	50	200	SN..1906.	2359-0028	2359-1028					

## 英制

MODEL	DIMENSIONS				FOR INSERT	ITEM NO.		SHIM	SHIM PIN	CLAMP	CLAMP SCREW	HEXKEY
	A	B	F	C		RIGHT	LEFT					
PSKNR/L 12-4C	0.75	0.75	1.00	5.0	SN..43.	2359-5012	2359-6012					
PSKNR/L 16-4D	1.00	1.00	1.25	6.0	SN..43.	2359-5013	2359-6013	S12A	GH0607	G0514-W	GL0822	
PSKNR/L 16-5D	1.00	1.00	1.25	6.0	SN..54.	2359-5014	2359-6014					S4
PSKNR/L 85-5E	1.00	1.25	1.25	7.0	SN..54.	2359-5016	2359-6016	S15A	GH0709	G0616-W	GL0826	
PSKNR/L 20-6E	1.25	1.25	1.50	7.0	SN..64.	2359-5018	2359-6012					
PSKNR/L 24-6F	1.50	1.50	2.00	8.0	SN..64.	2359-5020	2359-6020	S19A	GH0811	G0719-W	GL1031	S5





# Cutoutil

Metal Carbide Inserts, Turning Tools, Indexable Milling, Carbide Drill

www.cutoutil.com

## 45° 偏头端面车刀



SNMG, SNMA, SNMM

**PSSNR/L** 外圆, 端面加工

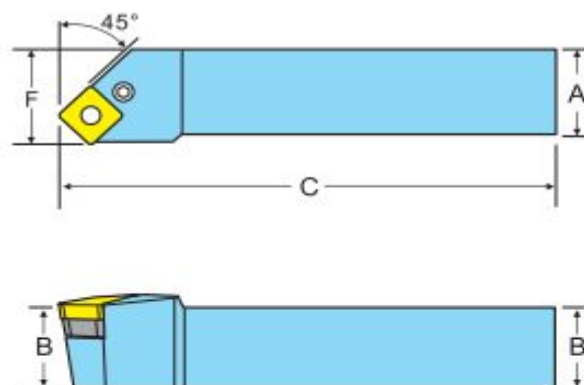

型号	刀体几何尺寸				适用刀片	产品货号		刀垫	弹簧套	杠杆	杠杆螺丝	扳手
	A	B	F	C		右刀	左刀					
PSSNR/L 1616H09	16	16	20	100	SN..0903.	2360-0012	2360-1012	S09A	GH0405	G0312-W	GL0617A	S3
PSSNR/L 2020K12	20	20	25	125	SN..1204.	2360-0014	2360-1014	S12A	GH0607	G0514-W	GL0822	S4
PSSNR/L 2020M12	20	20	25	150	SN..1204.	2360-0015	2360-1015					
PSSNR/L 2525M12	25	25	32	150	SN..1204.	2360-0016	2360-1016					
PSSNR/L 3232P12	32	32	40	170	SN..1204.	2360-0018	2360-1018					
PSSNR/L 2525M15	25	25	32	150	SN..1506.	2360-0020	2360-1020	S15A	GH0709	G0616-W	GL0826	
PSSNR/L 3225P15	25	32	32	170	SN..1506.	2360-0028	2360-1028					
PSSNR/L 3232P15	32	32	40	170	SN..1506.	2360-0022	2360-1022	S19A	GH0811	G0719-W	GL1031	S5
PSSNR/L 3232P19	32	32	40	170	SN..1906.	2360-0024	2360-1024					
PSSNR/L 4040R19	40	40	50	200	SN..1906.	2360-0026	2360-1026					

## 英制

MODEL	DIMENSIONS				FOR INSERT	ITEM NO.		SHIM	SHIM PIN	CLAMP	CLAMP SCREW	HEXKEY
	A	B	F	C		RIGHT	LEFT					
PSSNR/L 12-4C	0.75	0.75	1.00	5.0	SN..43.	2360-5012	2360-6012	S12A	GH0607	G0514-W	GL0822	S4
PSSNR/L 64-4D	0.75	1.00	1.00	6.0	SN..43.	2360-5014	2360-6014					
PSSNR/L 16-4D	1.00	1.00	1.25	6.0	SN..43.	2360-5015	2360-6015					
PSSNR/L 16-5D	1.00	1.00	1.25	6.0	SN..54.	2360-5016	2360-6016					
PSSNR/L 85-5E	1.00	1.25	1.25	7.0	SN..54.	2360-5018	2360-6018	S15A	GH0709	G0616-W	GL0826	
PSSNR/L 20-5E	1.25	1.25	1.50	7.0	SN..54.	2360-5019	2360-6019					
PSSNR/L 20-6E	1.25	1.25	1.50	7.0	SN..64.	2360-5020	2360-6020	S19A	GH0811	G0719-W	GL1031	S5
PSSNR/L 24-6F	1.50	1.50	2.00	8.0	SN..64.	2360-5022	2360-6022					





# Cutoutil

Metal Carbide Inserts, Turning Tools, Indexable Milling, Carbide Drill

www.cutoutil.com

## 45° 偏头外圆车刀



**PSDNN 外圆加工**

SNMG, SNMA, SNMM

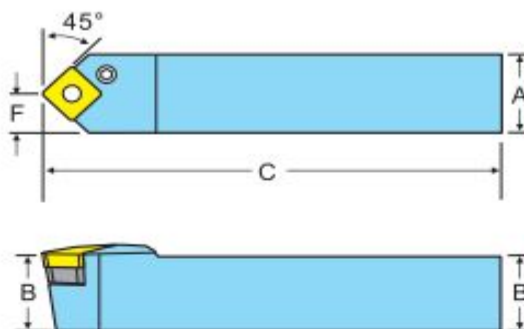

型号	刀体几何尺寸				适用刀片	产品货号					
	A	B	F	C			刀垫	弹簧套	杠杆	杠杆螺丝	扳手
PSDNN 1616H09	16	16	8	100	SN..0903.	2361-0010	S09A	GH0405	G0312-W	GL0617A	S3
PSDNN 2020K12	20	20	10	125	SN..1204.	2361-0012					
PSDNN 2525M12	25	25	12.5	150	SN..1204.	2361-0014	S12A	GH0607	G0514-W	GL0822	S4
PSDNN 3232P12	32	32	16	170	SN..1204.	2361-0016					
PSDNN 2525M15	25	25	12.5	150	SN..1506.	2361-0018	S15A	GH0709	G0616-W	GL0826	
PSDNN 3232P15	32	32	16	170	SN..1506.	2361-0020					
PSDNN 3232P19	32	32	16	170	SN..1906.	2361-0022	S19A	GH0811	G0719-W	GL1031	S5
PSDNN 4040R19	40	40	20	200	SN..1906.	2361-0024					

## 英制

MODEL	DIMENSIONS				FOR INSERT	ITEM NO.					
	A	B	F	C			SHIM	SHIM PIN	CLAMP	CLAMP SCREW	HEXKEY
PSDNN 12-4C	0.75	0.75	.375	5.0	SN..43.	2361-5012	S12A	GH0607	G0514-W	GL0822	S4
PSDNN 16-4D	1.00	1.00	.50	6.0	SN..43.	2361-5013					
PSDNN 16-5D	1.00	1.00	.50	6.0	SN..54.	2361-5014	S15A	GH0709	G0616-W	GL0826	
PSDNN 85-5E	1.00	1.25	.50	7.0	SN..54.	2361-5016					
PSDNN 20-6E	1.25	1.25	.625	7.0	SN..64.	2361-5018	S19A	GH0811	G0719-W	GL1031	S5
PSDNN 24-6F	1.50	1.50	.75	8.0	SN..64.	2361-5020					



# Cutoutil

Metal Carbide Inserts, Turning Tools, Indexable Milling, Carbide Drill

www.cutoutil.com

## 60° 偏头外圆端面车刀



TNMG, TNMA, TNMM

**PTTNR/L 外圆, 端面加工**

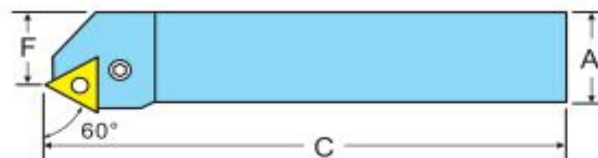

型号	刀体几何尺寸				适用刀片	产品货号		刀垫	弹簧套	杠杆	杠杆螺丝	扳手
	A	B	F	C		右刀	左刀					
PTTNR/L 2020K16	20	20	17	125	TN..1604.	2362-0014	2362-1014					
PTTNR/L 2520M16	20	25	17	150	TN..1604.	2362-0022	2362-1022	T16A	GH0405	G0310-W	GL0620	S3
PTTNR/L 2525M16	25	25	22	150	TN..1604.	2362-0024	2362-1024					
PTTNR/L 2525M22	25	25	22	150	TN..2204.	2362-0016	2362-1016					
PTTNR/L 3225P22	25	32	22	170	TN..2204.	2362-0018	2362-1018	T22A	GH0607	G0514-W	GL0822	S4
PTTNR/L 3232P22	32	32	27	170	TN..2204.	2362-0020	2362-1020					

## 英制

MODEL	DIMENSIONS				FOR INSERT	ITEM NO.		SHIM	SHIM PIN	CLAMP	CLAMP SCREW	HEXKEY
	A	B	F	C		RIGHT	LEFT					
PTTNR/L 12-3C	0.75	0.75	.63	5.0	TN..33.	2362-5012	2362-6012					
PTTNR/L 64-3D	0.75	1.00	.63	6.0	TN..33.	2362-5014	2362-6014	T16A	GH0405	G0310-W	GL0620	S3
PTTNR/L 16-3D	1.00	1.00	.88	6.0	TN..33.	2362-5013	2362-6013					
PTTNR/L 16-4D	1.00	1.00	.88	6.0	TN..43.	2362-5014	2362-6014	T22A	GH0607	G0514-W	GL0822	S4
PTTNR/L 85-4E	1.00	1.25	.88	7.0	TN..43.	2362-5018	2362-6018					







# Cutoutil

Metal Carbide Inserts, Turning Tools, Indexable Milling, Carbide Drill

www.cutoutil.com

## 90°偏头端面车刀



**PTGNR/L 外圆加工**

TNMG, TNMA, TNMM

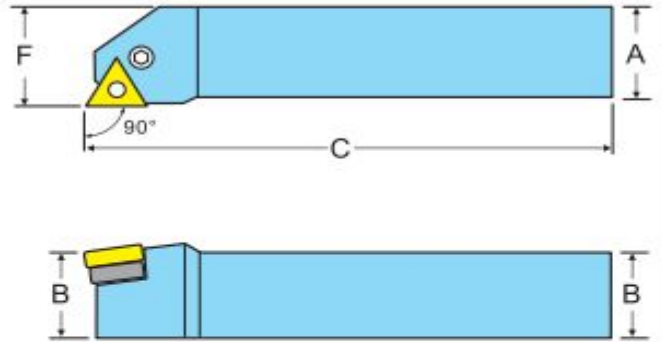

型号	刀体几何尺寸				适用刀片	产品货号		刀垫	弹簧套	杠杆	杠杆螺丝	扳手
	A	B	F	C		右刀	左刀					
PTGNR/L 1616H16	16	16	20	100	TN..1604.	2364-0018	2364-1018	T16A	GH0405	G0310-W	GL0620	S3
PTGNR/L 2020K16	20	20	25	125	TN..1604.	2364-0020	2364-1020					
PTGNR/L 2520M16	20	25	25	150	TN..1604.	2364-0021	2364-1021					
PTGNR/L 2525M16	25	25	32	150	TN..1604.	2364-0022	2364-1022					
PTGNR/L 3232P16	32	32	40	170	TN..1604.	2364-0024	2364-1024					
PTGNR/L 2525M22	25	25	32	150	TN..2204.	2364-0026	2364-1026	T22A	GH0607	G0514-W	GL0822	S4
PTGNR/L 3232P22	32	32	40	170	TN..2204.	2364-0028	2364-1028					

## 英制

MODEL	DIMENSIONS				FOR INSERT	ITEM NO.		SHIM	SHIM PIN	CLAMP	CLAMP SCREW	HEXKEY
	A	B	F	C		RIGHT	LEFT					
PTGNR/L 12-3C	0.75	0.75	1.00	5.0	TN..33.	2364-5012	2364-6012	T16A	GH0405	G0310-W	GL0620	S3
PTGNR/L 64-3D	0.75	1.00	1.00	6.0	TN..33.	2364-5014	2364-6014					
PTGNR/L 16-3D	1.00	1.00	1.25	6.0	TN..33.	2364-5015	2364-6015					
PTGNR/L 16-4D	1.00	1.00	1.25	6.0	TN..43.	2364-5016	2364-6016	T22A	GH0607	G0514-W	GL0822	S4
PTGNR/L 85-4E	1.00	1.25	1.25	7.0	TN..43.	2364-5018	2364-6018					



# Cutoutil

Metal Carbide Inserts, Turning Tools, Indexable Milling, Carbide Drill

www.cutoutil.com

## 95° 偏头外圆端面车刀



WNMM, WNMG, WNMA

**PWLNR/L 外圆，端面加工**

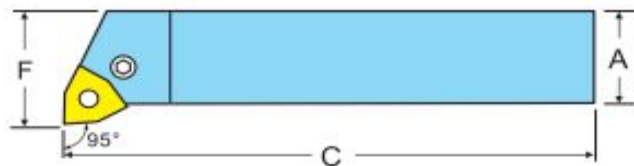

型号	刀体几何尺寸				适用刀片	产品货号		刀垫	弹簧套	杠杆	杠杆螺丝	扳手
	A	B	F	C		右刀	左刀					
PWLNR/L 1616H06	16	16	20	100	WN..0604.	2365-0012	2365-1012	W06A	GH0405	G0310-W	GL0620	S3
PWLNR/L 2020K06	20	20	25	125	WN..0604.	2365-0014	2365-1014	W08A	GH0607	G0514-W	GL0822	S4
PWLNR/L 2020K08	20	20	25	125	WN..0804.	2365-0018	2365-1018					
PWLNR/L 2520M08	20	25	25	125	WN..0804.	2365-0019	2365-1019	W10A	GH0709	G0616-W	GL0826	
PWLNR/L 2525M08	25	25	32	150	WN..0804.	2365-0020	2365-1020					
PWLNR/L 3225P08	25	32	32	170	WN..0804.	2365-0022	2365-1022					
PWLNR/L 3232P10	32	32	40	170	WN..1006.	2365-0024	2365-1024					

## 英制

MODEL	DIMENSIONS				FOR INSERT	ITEM NO.		SHIM	SHIM PIN	CLAMP	CLAMP SCREW	HEXKEY
	A	B	F	C		RIGHT	LEFT					
PWLNR/L 12-4C	0.75	0.75	1.00	5.0	WN..43.	2365-5012	2365-6012	W08A	GH0607	G0514-W	GL0822	S4
PWLNR/L 64-4D	0.75	1.00	1.00	6.0	WN..43.	2365-5014	2365-6014					
PWLNR/L 16-4D	1.00	1.00	1.25	6.0	WN..43.	2365-5015	2365-6015	W10A	GH0709	G0616-W	GL0826	
PWLNR/L 16-5D	1.00	1.00	1.25	6.0	WN..54.	2365-5016	2365-6016					
PWLNR/L 85-5E	1.00	1.25	1.25	7.0	WN..54.	2365-5018	2365-6018					
PWLNR/L 20-5E	1.25	1.25	1.50	7.0	WN..54.	2365-5020	2365-6020					



# Cutoutil

Metal Carbide Inserts, Turning Tools, Indexable Milling, Carbide Drill

www.cutoutil.com

## 90° 偏头外圆车刀



RNMG, RNMA, RNMM

## PRGNR/L 外圆加工

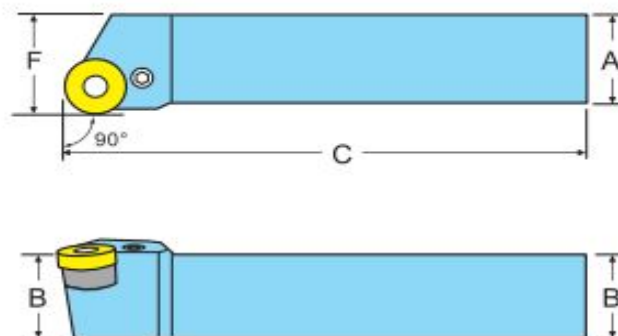

型号	刀体几何尺寸				适用刀片	产品货号		刀垫	弹簧套	缸杆	缸杆螺丝	扳手
	A	B	F	C		右刀	左刀					
PRGNR/L 2020K10	20	20	25	125	RN..1003.	2367-0014	2367-1014	R10A	GH0405	G0310-W	GL0620	S3
PRGNR/L 2525M12	25	25	32	150	RN..1204.	2367-0016	2367-1016	R12A	GH0607	G0514-W	GL0822	S4
PRGNR/L 3225P12	25	32	32	170	RN..1204.	2367-0018	2367-1018	R16A	GH0709	G0616-W	GL0826	
PRGNR/L 3232P16	32	32	40	170	RN..1605.	2367-0020	2367-1020					

## 英制

MODEL	DIMENSIONS				FOR INSERT	ITEM NO.		SHIM	SHIM PIN	CLAMP	CLAMP SCREW	HEXKEY
	A	B	F	C		RIGHT	LEFT					
PRGNR/L 16-4D	1.00	1.00	1.25	6.0	RN..43.	2367-5012	2367-6012	R12A	GH0607	G0514-W	LGL0822	S4
PRGNR/L 85-4E	1.00	1.25	1.25	7.0	RN..43.	2367-5013	2367-6013	R16A	GH0709	G0616-W	LGL0826	
PRGNR/L 20-5E	1.25	1.25	1.50	7.0	RN..53.	2367-5014	2367-6014					
PRGNR/L 85-5E	1.00	1.25	1.25	7.0	RN..53.	2367-5018	2367-6018					

## 车刀术语

### ◆ 表面粗糙度

· 理论表面粗糙度

$$R_{max} = \frac{F^2}{8r} 1000 (\mu)$$

· 实际表面粗糙度

钢 :  $R_{max} \times (1.5 \sim 3)$   
 铸铁 :  $R_{max} \times (3 \sim 5)$

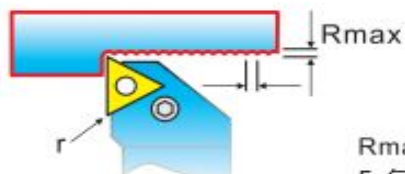

$R_{max}$ : 最大粗糙度 ( $\mu$ )  
 F: 每转进给  
 r: 刀具半径





# Cutoutil

Metal Carbide Inserts, Turning Tools, Indexable Milling, Carbide Drill

www.cutoutil.com

## 90° 偏头外圆车刀

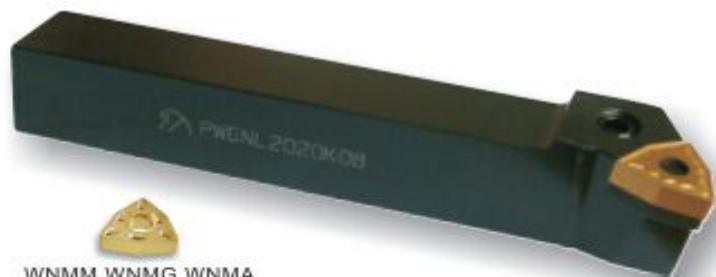

WNMM, WNMG, WNMA

**PWGNR/L 外圆, 端面加工**

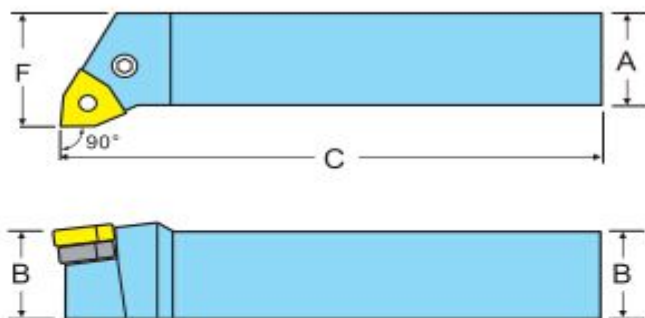

型号	刀体几何尺寸				通用刀片	产品货号		刀垫	弹簧套	杠杆	杠杆螺丝	扳手
	A	B	F	C		右刀	左刀					
PWGNR/L 2020K08	20	20	25	125	WN..0804.	2356-0012	2356-1012					
PWGNR/L 2520M08	20	25	25	150	WN..0804.	2356-0014	2356-1014	W08A	GH0607	G0514-W	GL0822	
PWGNR/L 2525M08	25	25	32	150	WN..0804.	2356-0016	2356-1016					S4
PWGNR/L 2525M10	25	25	32	150	WN..1006.	2356-0018	2356-1018	W10A	GH0709	G0616-W	GL0826	
PWGNR/L 3225P10	25	32	32	170	WN..1006.	2356-0020	2356-1020					
PWGNR/L 4032R13	32	40	40	200	WN..1307.	2356-0022	2356-1022	W13A	GH0811	G0719-W	GL1031	S5

## 英制

MODEL	DIMENSIONS				FOR INSERT	ITEM NO.		SHIM	SHIM PIN	CLAMP	CLAMP SCREW	HEXKEY
	A	B	F	C		RIGHT	LEFT					
PWGNR/L 12-4C	0.75	0.75	1.00	5.0	WN..43.	2356-5012	2356-6012					
PWGNR/L 64-4D	0.75	1.00	1.00	6.0	WN..43.	2356-5014	2356-6014	W08A	GH0607	G0514-W	GL0822	
PWGNR/L 16-4D	1.00	1.00	1.25	6.0	WN..43.	2356-5016	2356-6016					S4
PWGNR/L 16-5D	1.00	1.00	1.25	6.0	WN..54.	2356-5018	2356-6018	W10A	GH0709	G0616-W	GL0826	
PWGNR/L 85-5E	1.00	1.25	1.25	7.0	WN..54.	2356-5020	2356-6020					





# Cutoutil

Metal Carbide Inserts, Turning Tools, Indexable Milling, Carbide Drill

www.cutoutil.com

## 60° 偏头外圆车刀



## PCTNR/L 外圆加工

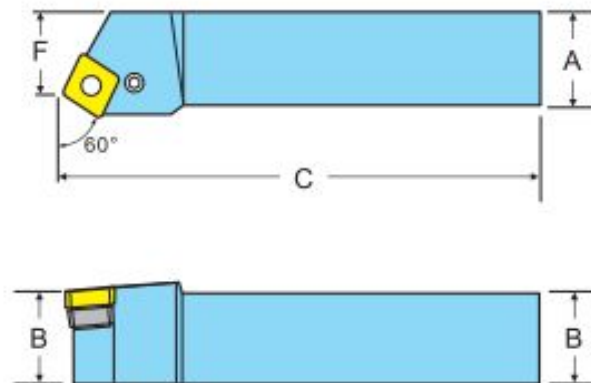

型号	刀体几何尺寸				通用刀片	产品货号		刀垫	弹簧套	杠杆	杠杆螺丝	扳手
	A	B	F	C		右刀	左刀					
PCTNR/L 2020K12	20	20	17	125	CN..1204.	2370-0010	2370-1010	C12A	GH0607	G0514-W	GL0822	
PCTNR/L 2525M12	25	25	22	150	CN..1204.	2370-0012	2370-1012					
PCTNR/L 2525M16	25	25	22	150	CN..1606.	2370-0014	2370-1014					S4
PCTNR/L 3225P16	25	32	22	170	CN..1606.	2370-0016	2370-1016	C16A	GH0709	G0616-W	GL0826	
PCTNR/L 3232P16	32	32	27	170	CN..1606.	2370-0018	2370-1018					
PCTNR/L 3232P19	32	32	27	170	CN..1906.	2370-0020	2370-1020					
PCTNR/L 4040R19	40	40	35	200	CN..1906.	2370-0022	2370-1022	C19A	GH0811	G0719-W	GL1031	S5

## 英制

MODEL	DIMENSIONS				FOR INSERT	ITEM NO.		SHIM	SHIM PIN	CLAMP	CLAMP SCREW	HEXKEY
	A	B	F	C		RIGHT	LEFT					
PCTNR/L 12-4C	0.75	0.75	.88	5.0	CN..43.	2370-5012	2370-6012	C12A	GH0607	G0514-W	GL0822	
PCTNR/L 16-4D	1.00	1.00	1.13	6.0	CN..43.	2370-5014	2370-6014					
PCTNR/L 16-5D	1.00	1.00	1.13	6.0	CN..54.	2370-5016	2370-6016					S4
PCTNR/L 20-5E	1.25	1.25	1.31	7.0	CN..54.	2370-5018	2370-6018	C16A	GH0709	G0616-W	GL0826	
PCTNR/L 20-6E	1.25	1.25	1.31	7.0	CN..64.	2370-5020	2370-6020	C19A	GH0811	G0719-W	GL1031	S5





# Cutoutil

Metal Carbide Inserts, Turning Tools, Indexable Milling, Carbide Drill

www.cutoutil.com

## 75° 偏头外圆车刀



SNMG, SNMA, SNMM

### PSRNR/L 外圆加工

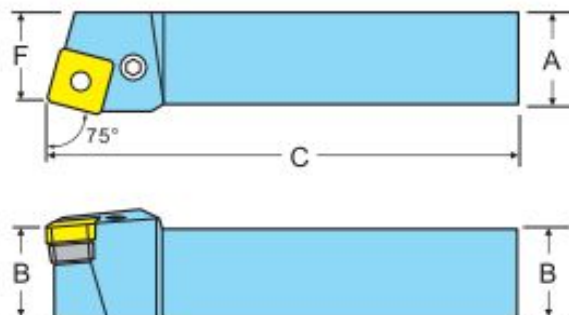

型号	刀体几何尺寸				适用刀片	产品货号		刀垫	弹簧套	杠杆	杠杆螺丝	扳手
	A	B	F	C		右刀	左刀					
PSRNR/L 2020K12	20	20	22	125	SN..1204.	2371-0012	2371-1012					
PSRNR/L 2520M12	20	25	22	150	SN..1204.	2371-0014	2371-1014	S12A	GH0607	G0514-W	GL0822	
PSRNR/L 2525M12	25	25	27	150	SN..1204.	2371-0016	2371-1016					S4
PSRNR/L 2525M15	25	25	27	150	SN..1506.	2371-0018	2371-1018	S15A	GH0709	G0616-W	GL0826	
PSRNR/L 3225P15	25	32	27	170	SN..1506.	2371-0020	2371-1020					
PSRNR/L 4032R19	32	40	35	200	SN..1906.	2371-0022	2371-1022	S19A	GH0811	G0719-W	GL1031	S5

## 英制

MODEL	DIMENSIONS				FOR INSERT	ITEM NO.		SHIM	SHIM PIN	CLAMP	CLAMP SCREW	HEXKEY
	A	B	F	C		RIGHT	LEFT					
PSRNR/L 12-4C	0.75	0.75	.88	5.0	CN..43.	2371-5012	2371-6012					
PSRNR/L 16-4D	1.00	1.00	1.13	5.0	CN..43.	2371-5014	2371-6014	S12A	GH0607	G0514-W	GL0822	
PSRNR/L 16-5D	1.00	1.00	1.13	6.0	CN..54.	2371-5016	2371-6016					S4
PSRNR/L 20-5E	1.25	1.25	1.35	7.0	CN..54.	2371-5018	2371-6018	S15A	GH0709	G0616-W	GL0826	



# Cutoutil

Metal Carbide Inserts, Turning Tools, Indexable Milling, Carbide Drill

www.cutoutil.com

## 93° 偏头外圆车刀



KNUX160405R/L

**CKJNR/L 外圆加工**

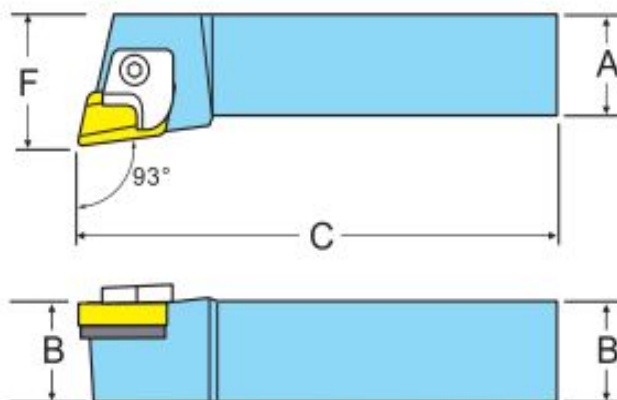

型号	刀体几何尺寸				通用刀片	产品货号	刀垫	刀垫螺钉	压板	支撑销	螺丝	大弹簧	小弹簧	扳手							
	A	B	F	C																	
CKJNR 2020K16	20	20	30	125	KNUX1604R	2390-0008	CKJNR16-7	M3x8	CKJNR16-4	CKJNR16-5	CKJNR16-3	CKJNR16-2	CKJNR16-6	S4							
CKJNR 2525M16	25	25	32	150	KNUX1604R	2390-0010															
CKJNR 3225P16	25	32	32	170	KNUX1604R	2390-0012															
CKJNL 2020K16	20	20	30	125	KNUX1604L	2390-1008									CKJNL16-7	CKJNL16-4	CKJNR16-5	CKJNR16-3	CKJNR16-2	CKJNR16-6	S4
CKJNL 2525M16	25	25	32	150	KNUX1604L	2390-1010															
CKJNL 3225P16	25	32	32	170	KNUX1604L	2390-1012															

## CKJNR/L 配套零件

	右刀 ORDER #	左刀 ORDER #
	2390-0164	2390-1164
<b>KNUX160405</b>	Tin-Coated 2390-5164	Tin-Coated 2390-6164
压爪	2390-1001	2390-1002
压爪螺钉	2390-1010	2390-1012
刀垫	2390-1050	2390-1051
支撑销	2390-1060	2390-1061
刀垫螺钉	2390-1031	2390-1032
大弹簧	2390-1013	2390-1014
小弹簧	2390-1015	2390-1016



# Cutoutil

Metal Carbide Inserts, Turning Tools, Indexable Milling, Carbide Drill

www.cutoutil.com

## 90° 偏头外圆车刀



**CTGPR/L** 车削加工，外圆加工

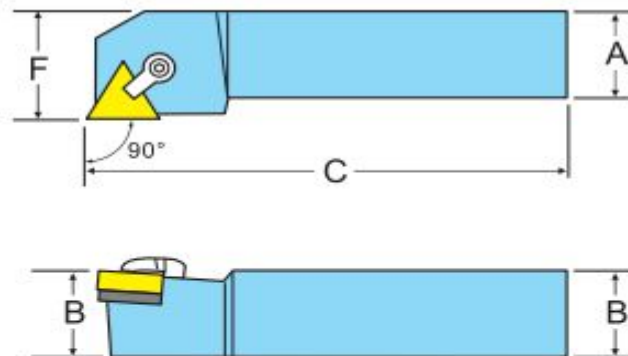

型号	刀体几何尺寸				适用刀片	产品货号		刀垫	刀垫螺钉	压板	双头螺丝	扳手
	A	B	F	C		右刀	左刀					
CTGPR/L 1212H11	12	12	16	100	TPG110204	2391-0004	2391-1004	TP11D	M2.5x8		XNS-0517	
CTGPR/L 1616H16	16	16	20	100	TPG160304	2391-0006	2391-1006	TP16D	M3x8	CL-6	XNS-0520	S1.5,S2.5
CTGPR/L 2020K16	20	20	25	125	TPG160304	2391-0008	2391-1008			CL-12	XNS-0829	S1.5,S4
CTGPR/L 2525M22	25	25	32	150	TPG220404	2391-0010	2391-1010					
CTGPR/L 3225P22	25	32	32	170	TPG220404	2391-0012	2391-1012	TP22D				
CTGPR/L 3232P22	32	32	40	170	TPG220404	2391-0014	2391-1014					

## 英制

MODEL	DIMENSIONS				FOR INSERT	ITEM NO.		SHIM	SHIM PIN	CLAMP	CLAMP SCREW	HEXKEY
	A	B	F	C		RIGHT	LEFT					
CTGPR/L10-3B	.625	.625	.75	4.5	TPG321	2391-2008	2391-3008	TP16D	M3x8	CL-6	XNS-0520	S1.5,S2.5
CTGPR/L12-3B	.75	.75	1.00	4.5	TPG321	2391-2010	2391-3010			CL-12	XNS-0829	S1.5,S4
CTGPR/L16-4D	1.00	1.00	1.25	6.0	TPG431	2391-2012	2391-3012	TP22D				
CTGPR/L20-4D	1.25	1.25	1.50	6.0	TPG431	2391-2014	2391-3014					





# Cutoutil

Metal Carbide Inserts, Turning Tools, Indexable Milling, Carbide Drill

www.cutoutil.com

## 90° 偏头端面车刀



## CTFPR/L 端面加工

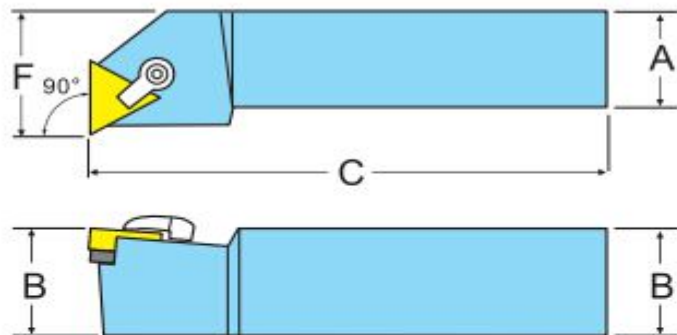

型号	刀体几何尺寸				适用刀片	产品货号		刀垫	刀垫螺钉	压板	双头螺丝	扳手
	A	B	F	C		右刀	左刀					
CTFPR/L1212F11	12	12	16	80	TPG110304	2392-0008	2392-1008	TP11D	M2.5x8		XNS-0517	
CTFPR/L1616H16	16	16	20	100	TPG160304	2392-0010	2392-1010	TP16D	M3x8	C-L6	XNS-0520	S1.5,S2.5
CTFPR/L2020K16	20	20	25	125	TPG160304	2392-0012	2392-1012					
CTFPR/L2525M22	25	25	32	150	TPG220404	2392-0014	2392-1014	TP22D		CL-12	XNS-0829	S1.5,S4
CTFPR/L3232P22	32	32	40	170	TPG220404	2392-0016	2392-1016					

## 英制

MODEL	DIMENSIONS				FOR INSERT	ITEM NO.		SHIM	SHIM PIN	CLAMP	CLAMP SCREW	HEXKEY
	A	B	F	C		RIGHT	LEFT					
CTFPR/L 08-2	.50	.50	.625	2.5	TPG221	2392-2008	2392-3008	TP11D	M2.5x8		XNS-0517	
CTFPR/L 10-2	.625	.625	.75	2.75	TPG221	2392-2010	2392-3010			CL-6		S1.5,S2.5
CTFPR/L 10-3B	.625	.625	.75	4.5	TPG321	2392-2012	2392-3012	TP16D	M3x8			
CTFPR/L 12-3C	.75	.75	1.00	5.0	TPG321	2392-2014	2392-3014					
CTFPR/L 16-3D	1.00	1.00	1.00	6.0	TPG321	2392-2016	2392-3016					
CTFPR/L 12-4B	.75	.75	1.25	4.5	TPG431	2392-2018	2392-3018			CL-12		S1.5,S4
CTFPR/L 16-4D	1.00	1.00	1.25	6.0	TPG431	2392-2020	2392-3020	TP22D				
CTFPR/L 20-4D	1.25	1.25	1.50	6.0	TPG431	2392-2022	2392-3022					



# Cutoutil

Metal Carbide Inserts, Turning Tools, Indexable Milling, Carbide Drill

www.cutoutil.com

## 90°直头外圆车刀

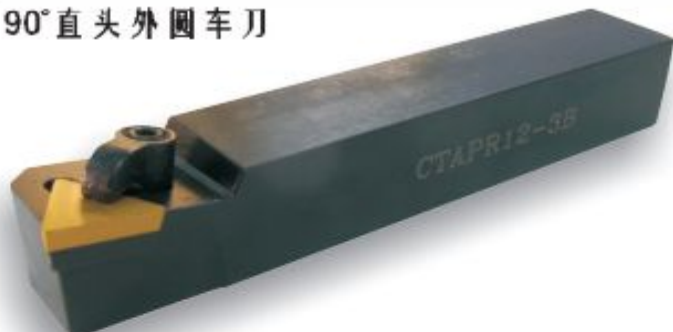

**CTAPR/L** 车削加工, 外圆加工

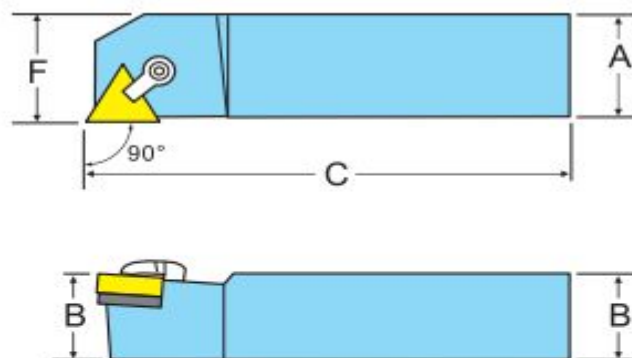

型号	刀体几何尺寸				适用刀片	产品货号		刀垫	刀垫螺钉	压板	双头螺丝	扳手
	A	B	F	C		右刀	左刀					
CTAPR/L1212F11	12	12	12	80	TPG110304	2393-0008	2393-1008	TP11D	M2.5x8		XNS-0517	
CTAPR/L1616H16	16	16	16	100	TPG160304	2393-0010	2393-1010	TP16D	M3x8	CL-6	XNS-0520	S1.5,S2.5
CTAPR/L2020K16	20	20	20	125	TPG160304	2393-0012	2393-1012	TP22D		CL-12	XNS-0829	S1.5,S4
CTAPR/L2525M22	25	25	25	150	TPG220404	2393-0014	2393-1014					
CTAPR/L3232P22	32	32	32	170	TPG220404	2393-0016	2393-1016					

英制

MODEL	DIMENSIONS FOR				INSERT	ITEM NO.		SHIM	SHIM PIN	CLAMP	CLAMP SCREW	HEXKEY
	A	B	F	C		RIGHT	LEFT					
CTAPR/L 06-2J	.375	.375	.375	3.5	TPG221	2393-2006	2393-3006	TP11D	M2.5x8		XNS-0517	
CTAPR/L 08-2J	.50	.50	.50	3.5	TPG221	2393-2008	2393-3008	TP16D	M3x8	CL-6	XNS-0520	S1.5,S2.5
CTAPR/L 10-3B	.625	.625	.625	4.5	TPG321	2393-2010	2393-3010	TP22D		CL-12	XNS-0829	S1.5,S4
CTAPR/L 12-3B	.75	.75	.75	4.5	TPG321	2393-2012	2393-3012					
CTAPR/L 16-3D	1.00	1.00	1.00	6.0	TPG321	2393-2014	2393-3014					
CTAPR/L 16-4D	1.25	1.25	1.25	6.0	TPG431	2393-2016	2393-3016					



# Cutoutil

Metal Carbide Inserts, Turning Tools, Indexable Milling, Carbide Drill

www.cutoutil.com

## 楔压式93°偏头外圆车刀



WTJNR/L 外圆加工

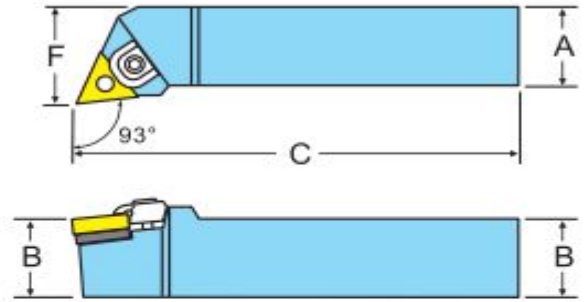

型号	刀体几何尺寸				适用刀片	产品货号		刀垫	锁紧销	压板	压板螺丝	扳手·卡圈
	A	B	F	C		右刀	左刀					
WTJNR/L1616H16	16	16	22	100	TNMG160408	2394-0010	2394-1010	WST163	WSP30514			
WTJNR/L2020K16	20	20	25	125	TNMG160408	2394-0012	2394-1012					
WTJNR/L2525M16	25	25	32	150	TNMG160408	2394-0014	2394-1014			X1518	M5x20	S2.5,S4,E4
WTJNR/L3225P16	25	32	32	170	TNMG160408	2394-0016	2394-1016	WST164	WSP40517			
WTJNR/L3232P16	32	32	40	170	TNMG160408	2394-0018	2394-1018					
WTJNR/L2525M22	25	25	32	150	TNMG220408	2394-0020	2394-1020					
WTJNR/L3232P22	32	32	40	170	TNMG220408	2394-0022	2394-1022	WST224	WSP40617	X1922	M6x25	S3,S5,E5

## 英制

MODEL	DIMENSIONS				FOR INSERT	ITEM NO.		SHIM	SHIM PIN	CLAMP	CLAMP SCREW	HEXKEY CLIPS
	A	B	F	C		RIGHT	LEFT					
WTJNR/L 10-3B	.625	.625	.86	4.5	TN..33	2394-2006	2394-3006	WST163	WSP30514			
WTJNR/L 12-3B	.75	.75	1.00	4.5	TN..33	2394-2008	2394-3008					
WTJNR/L 16-3D	1.00	1.00	1.25	6.0	TN..33	2394-2010	2394-3010	WST164	WSP40517	X1518	M5x20	S2.5,S4,E4
WTJNR/L 85-3D	1.00	1.25	1.25	6.0	TN..33	2394-2012	2394-3012					
WTJNR/L 16-4D	1.00	1.00	1.25	6.0	TN..43	2394-2014	2394-3014	WST224	WSP40617	X1922	M6x25	S3,S5,E5
WTJNR/L 85-4E	1.00	1.25	1.25	7.0	TN..43	2394-2016	2394-3016					





# Cutoutil

Metal Carbide Inserts, Turning Tools, Indexable Milling, Carbide Drill

www.cutoutil.com

## 楔压式60°直头外圆车刀

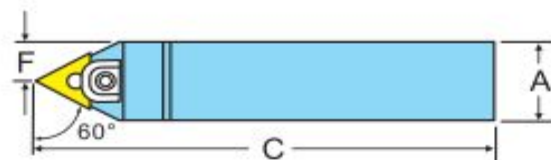

**WTENN** 车削加工, 外圆加工

型号	刀体几何尺寸				适用刀片	产品货号							
	A	B	F	C			刀垫	锁紧销	压板	压板螺丝	扳手·卡圈		
WTENN1616H16	16	16	8	100	TNMG1604	2395-0010	WST163	WSP30514					
WTENN2020K16	20	20	10	125	TNMG1604	2395-0012							
WTENN2525M16	25	25	12.5	150	TNMG1604	2395-0014	WST164	WSP40517	X1518	M5x20	S2.5,S4,E4		
WTENN3225P16	25	32	12.5	170	TNMG1604	2395-0016							
WTENN2525M22	25	25	12.5	150	TNMG2204	2395-0018							
WTENN3225P22	25	32	12.5	170	TNMG2204	2395-0020	WST224	WSP40617	X1922	M6x25	S3,S5,E5		
WTENN3232P22	32	32	16	170	TNMG2204	2395-0022							

## 英制

MODEL	DIMENSIONS FOR				INSERT	ITEM NO.						
	A	B	F	C			SHIM	SHIM PIN	CLAMP	CLAMP SCREW	HEXKEY CLIPS	
WTENN10-3B	.625	.625	.312	4.5	TNMG332	2395-2010	WST163	WSP30514				
WTENN12-3B	.75	.75	.375	4.5	TNMG332	2395-2012						
WTENN16-3D	1.00	1.00	.50	6.0	TNMG332	2395-2014	WST164	WSP40517	X1518	M5x20	S2.5,S4,E4	
WTENN85-3E	1.00	1.25	.50	7.0	TNMG332	2395-2016						
WTENN16-4D	1.00	1.00	.50	6.0	TNMG432	2395-2018						
WTENN85-4E	1.00	1.25	.50	7.0	TNMG432	2395-2020	WST224	WSP40617	X1922	M6x25	S3,S5,E5	
WTENN20-4E	1.25	1.25	.625	7.0	TNMG432	2395-2022						





# Cutoutil

Metal Carbide Inserts, Turning Tools, Indexable Milling, Carbide Drill

www.cutoutil.com

楔压式95°偏头外圆，端面车刀



WWLNR/L 外圆，端面加工

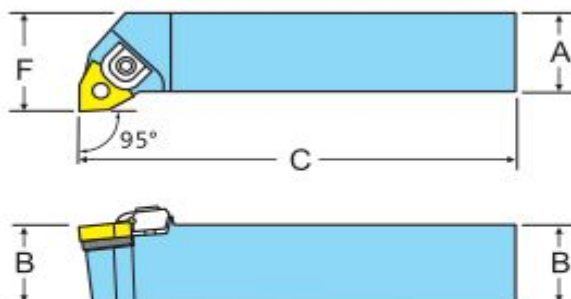

型号	刀体几何尺寸				适用刀片	产品货号		刀垫	锁紧销	压板	压板螺丝	扳手·卡圈
	A	B	F	C		右刀	左刀					
WWLNR/L 2020K08	20	20	25	125	WNMG0804	2397-0008	2397-1008					
WWLNR/L 2525M08	25	25	32	150	WNMG0804	2397-0010	2397-1010	WSW084	WSP40617	WW08C	M5x20	S3,S4,E4
WWLNR/L 3225P08	25	32	32	170	WNMG0804	2397-0012	2397-1012					

英制

MODEL	DIMENSIONS				FOR INSERT	ITEM NO.		SHIM	SHIM PIN	CLAMP	CLAMP SCREW	HEXKEY CLIPS
	A	B	F	C		RIGHT	LEFT					
WWLNR/L 12-4C	.75	.75	1.00	5.0	TNMG432	2397-5008	2397-6008					
WWLNR/L 16-4D	1.00	1.00	1.25	6.0	TNMG432	2397-5010	2397-6010	WSW084	WSP40617	WW08C	M5x20	S3,S4,E4
WWLNR/L 85-4D	1.00	1.25	1.25	6.0	TNMG432	2397-5012	2397-6012					





# Cutoutil

Metal Carbide Inserts, Turning Tools, Indexable Milling, Carbide Drill

www.cutoutil.com

## 楔压式107.5°外圆车刀

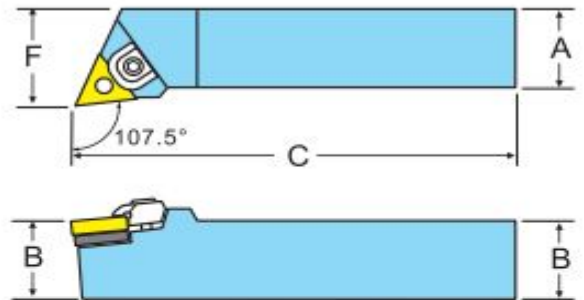

TNMG

## WTQNR/L 外圆加工

型号	刀体几何尺寸				适用刀片	产品货号		刀垫	锁紧销	压板	压板螺丝	扳手·卡圈
	A	B	F	C		右刀	左刀					
WTQNR/L 2020K16	20	20	25	125	TNMG1604	2398-0010	2398-1010	WST164	WSP40517	X1518	M5x20	S2.5,S4,E4
WTQNR/L 2525M16	25	25	32	150	TNMG1604	2398-0012	2398-1012					
WTQNR/L 3225P16	25	32	32	170	TNMG1604	2398-0014	2398-1014					
WTQNR/L 3232P16	32	32	40	170	TNMG1604	2398-0016	2398-1016					

## 英制

MODEL	DIMENSIONS				FOR INSERT	ITEM NO.		SHIM	SHIM PIN	CLAMP	CLAMP SCREW	HEXKEY CLIPS
	A	B	F	C		RIGHT	LEFT					
WTQNR/L 12-3C	.75	.75	1.00	5.0	TN..332	2398-5008	2398-6008	WST164	WSP40517	X1518	M5x20	S2.5,S4,E4
WTQNR/L 16-3D	1.00	1.00	1.25	6.0	TN..332	2398-5010	2398-6010					
WTQNR/L 85-3D	1.00	1.25	1.25	6.0	TN..332	2398-5012	2398-6012					
WTQNR/L 20-3E	1.25	1.25	1.50	7.0	TN..332	2398-5014	2398-6014					



# Cutoutil

Metal Carbide Inserts, Turning Tools, Indexable Milling, Carbide Drill

www.cutoutil.com

## 技术术语

### 表面粗糙度

种类	代号	求解方法	求解方法例子 (图)
算术平均粗糙度	Ra	<p>从粗糙度曲线, 在其平均线方向, 只取标准长度, 将其取出部分平均线方向定为X轴, 在垂直方向放大倍数的方向上定为Y轴, 用<math>Y = f(X)</math>表示粗糙度曲线时, 由下式求得用微米 (<math>\mu\text{m}</math>) 单位表示。</p> $Ra = \frac{1}{l} \int_0^l  f(x)  dx$	
算术平均粗糙度	Rz	<p>从粗糙度曲线, 在其平均线方向只取标准长度, 在粗糙度曲线的垂直放大倍数的方向上, 测定该取出部分的峰顶线和谷底线之间的距离, 用微米 (<math>\mu\text{m}</math>) 单位表示测得值。</p> $Rz = R_p + R_v$	
十点平均粗糙度	RzJIS	<p>从粗糙度曲线, 在其平均线方向只取标准长度, 选取5个连续的波谷计算出平均值 (绝对值), 再将两个值求和, 用微米 (<math>\mu\text{m}</math>) 表示。</p> <p><math>Y_{p1} \dots Y_{p5}</math>: 取标准长度的5个连续峰值</p> <p><math>Y_{v1} \dots Y_{v5}</math>: 取标准长度的5个连续峰谷</p>	$RzJIS = \frac{(Y_{p1} + Y_{p2} + Y_{p3} + Y_{p4} + Y_{p5}) + (Y_{v1} + Y_{v2} + Y_{v3} + Y_{v4} + Y_{v5})}{5}$



# Cutoutil

Metal Carbide Inserts, Turning Tools, Indexable Milling, Carbide Drill

www.cutoutil.com

## 螺钉压紧结构外圆车刀

**特点:**  
无刀垫设计, 结构简单合理, 适合小余量精密加工。  
用户在更换刀片时更加方便, 快捷。

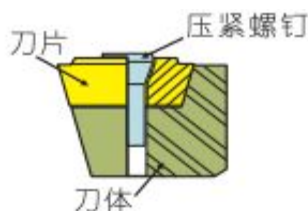

## SCLCR/L 外圆加工

型号	刀体几何尺寸				适用刀片	产品货号		螺丝	扳手
	A	B	F	C		右刀	左刀		
SCLCR/L0808D06	8	8	10	60	CCMT0602.	2370-0004	2370-1004	M2.5x8	T8
SCLCR/L1010E06	10	10	12	70	CCMT0602.	2370-0006	2370-1006		
SCLCR/L1212F09	12	12	16	80	CCMT09T3.	2370-0008	2370-1008	M4x10	T15
SCLCR/L1616H09	16	16	20	100	CCMT09T3.	2370-0010	2370-1010		
SCLCR/L2020K12	20	20	25	125	CCMT1204.	2370-0012	2370-1012	M5x12	T20
SCLCR/L2525M12	25	25	26	150	CCMT1204.	2370-0014	2370-1014		
SCLCR/L3232P12	32	32	26	170	CCMT1204.	2370-0016	2370-1016		

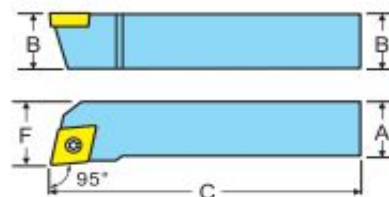

MODEL	DIMENSIONS				FOR INSERT	ITEM NO.		SCREW	WRENCH KEY
	A	B	F	C		RIGHT	LEFT		
SCLCR/L06-2J	3/8	3/8	.5	3.5	CCMT21.5.	2370-5004	2370-6004	M2.5x8	T8
SCLCR/L08-3A	1/2	1/2	.625	4.0	CCMT32.5.	2370-5006	2370-6006		
SCLCR/L10-3B	5/8	5/8	.75	4.5	CCMT32.5.	2370-5008	2370-6008	M4x10	T15
SCLCR/L12-3B	3/4	3/4	1.00	4.5	CCMT32.5.	2370-5010	2370-6010		
SCLCR/L12-4B	3/4	3/4	1.00	4.5	CCMT43.	2370-5011	2370-6011	M5x12	T20
SCLCR/L16-4D	1	1	1.25	6.0	CCMT43.	2370-5012	2370-6012		

## SDJCR/L 外圆加工

型号	刀体几何尺寸				适用刀片	产品货号		螺丝	扳手
	A	B	F	C		右刀	左刀		
SDJCR/L1010E07	10	10	12	70	DCMT0702.	2371-0004	2371-1004	M2.5x8	T8
SDJCR/L1212F07	12	12	16	80	DCMT0702.	2371-0006	2371-1006		
SDJCR/L1616H07	16	16	20	100	DCMT0702.	2371-0008	2371-1008	M4x10	T15
SDJCR/L1616H11	16	16	20	100	DCMT11T3.	2371-0010	2371-1010		
SDJCR/L2020K11	20	20	25	125	DCMT11T3.	2371-0012	2371-1012	M4x10	T15
SDJCR/L2525M11	25	25	32	150	DCMT11T3.	2371-0014	2371-1014		
SDJCR/L3225P11	25	32	32	170	DCMT11T3.	2371-0016	2371-1016		

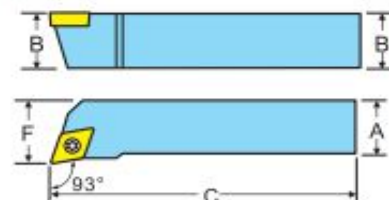

MODEL	DIMENSIONS				FOR INSERT	ITEM NO.		SCREW	WRENCH KEY
	A	B	F	C		RIGHT	LEFT		
SDJCR/L06-2J	3/8	3/8	.50	3.5	DCMT21.5.	2371-5004	2371-6004	M2.5x8	T8
SDJCR/L08-2A	1/2	1/2	.625	4	DCMT21.5.	2371-5005	2371-6005		
SDJCR/L08-3A	1/2	1/2	.625	4	DCMT32.5.	2371-5006	2371-6006	M4x10	T15
SDJCR/L10-3B	5/8	5/8	.75	4.5	DCMT32.5.	2371-5008	2371-6008		
SDJCR/L12-3B	3/4	3/4	1.00	4.5	DCMT32.5.	2371-5010	2371-6010		





# Cutoutil

Metal Carbide Inserts, Turning Tools, Indexable Milling, Carbide Drill

www.cutoutil.com

## SSDCN 45° 外圆加工

型号	刀体几何尺寸				适用刀片	产品货号	螺丝	扳手
	A	B	F	C				
SSDCN0808D06	8	8	4	60	SCMT0602	2378-0006	M2.5x8	T8
SSDCN1010E06	10	10	5	70	SCMT0602	2378-0008		
SSDCN1212F06	16	16	8	80	SCMT0602	2378-0010	M4x10	T15
SSDCN1616H09	12	12	6	100	SCMT09T3	2378-0012		
SSDCN2020K09	16	16	8	125	SCMT09T3	2378-0014	M5x12	T20
SSDCN1616H12	20	20	10	100	SCMT1204	2378-0016		
SSDCN2020K12	25	25	12.5	150	SCMT1204	2378-0018	M5x12	T20
SSDCN2525M12	25	25	12.5	150	SCMT1204	2378-0020		

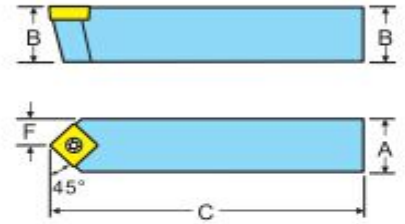

MODEL	DIMENSIONS				FOR INSERT	ITEM NO.	SCREW	WRENCH KEY
	A	B	F	C				
SSDCN06-2J	3/8	3/8	.188	3.5	SCMT21.5	2378-5008	M2.5x8	T8
SSDCN08-3A	1/2	1/2	.25	4	SCMT32.5	2378-5010	M4x10	T15
SSDCN10-3B	5/8	5/8	.313	4.5	SCMT32.5	2378-5012		
SSDCN12-3B	3/4	3/4	.375	4.5	SCMT32.5	2378-5014	M5x12	T20
SSDCN12-4B	3/4	3/4	.375	4.5	SCMT32.5	2378-5016		
SSDCN16-4D	1	1	.50	6	SCMT432	2378-5018		

## SVJCR/L 93° 外圆，仿形加工

型号	刀体几何尺寸				通用刀片	产品货号		螺丝	扳手
	A	B	F	C		右刀	左刀		
SVJCR/L1212H11	12	12	16	100	VCMT1102	2373-0106	2373-1106	M2.5x8	T8
SVJCR/L1616H11	16	16	20	100	VCMT1102	2373-0108	2373-1108		
SVJCR/L2020K11	20	20	25	125	VCMT1102	2373-0110	2373-1110	M4x10	T15
SVJCR/L2525M11	25	25	32	150	VCMT1102	2373-0112	2373-1112		
SVJCR/L1616H16	16	16	20	100	VCMT1604	2373-0114	2373-1114	M4x10	T15
SVJCR/L2020K16	20	20	25	125	VCMT1604	2373-0116	2373-1116		
SVJCR/L2525M16	25	25	32	150	VCMT1604	2373-0118	2373-1118	M4x10	T15
SVJCR/L3225P16	25	32	32	170	VCMT1604	2373-0120	2373-1120		

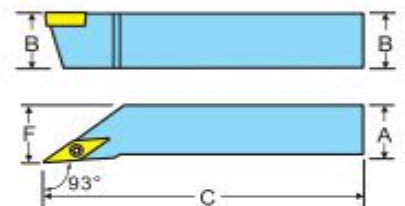

MODEL	DIMENSIONS				FOR INSERT	ITEM NO.		SCREW	WRENCH KEY
	A	B	F	C		RIGHT	LEFT		
SVJCR/L06-2J	3/8	3/8	.50	3.5	VCMT21.5	2373-5108	2373-6108	M2.5x8	T8
SVJCR/L08-2A	1/2	1/2	.625	4	VCMT21.5	2373-5110	2373-6110		
SVJCR/L10-2B	5/8	5/8	.75	4.5	VCMT21.5	2373-5112	2373-6112	M4x10	T15
SVJCR/L12-3B	3/4	3/4	1	4.5	VCMT33	2373-5114	2373-6114		
SVJCR/L16-3C	1	1	1.25	5	VCMT33	2373-5116	2373-6116	M4x10	T15
SVJCR/L16-3D	1	1	1.25	6	VCMT33	2373-5118	2373-6118		



# Cutoutil

Metal Carbide Inserts, Turning Tools, Indexable Milling, Carbide Drill

www.cutoutil.com

## SDNCN 72.5° 仿形加工

型号	刀体几何尺寸				通用刀片	产品货号		螺丝	扳手
	A	B	F	C					
SDNCN1010E07	10	10	5	70	DCMT0702.	2372-0004		M2.5x8	T8
SDNCN1212F07	12	12	6	80	DCMT0702.	2372-0006			
SDNCN1616H07	16	16	8	100	DCMT0702.	2372-0007			
SDNCN1212F11	12	12	6	80	DCMT11T3.	2372-0008		M4x10	T15
SDNCN1616H11	16	16	8	100	DCMT11T3.	2372-0010			
SDNCN2020K11	20	20	10	125	DCMT11T3.	2372-0012			
SDNCN2525M11	25	25	12.5	150	DCMT11T3.	2372-0014			

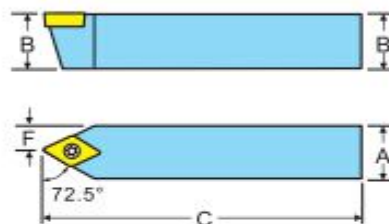

MODEL	DIMENSIONS				FOR INSERT	ITEM NO.	SCREW	WRENCH KEY
	A	B	F	C				
SDNCN06-2J	3/8	3/8	.188	3.5	DCMT21.5.	2372-5004	M2.5x8	T8
SDNCN08-3A	1/2	1/2	.25	4	DCMT32.5.	2372-5006	M4x10	T15
SDNCN10-3B	5/8	5/8	.313	4.5	DCMT32.5.	2372-5008		
SDNCN12-3B	3/4	3/4	.925	4.5	DCMT32.5.	2372-5010		
SDNCN16-3D	1	1	.50	6	DCMT32.5.	2372-5012		

## SVJBR/L 93° 外圆，仿形加工

型号	刀体几何尺寸				通用刀片	产品货号		螺丝	扳手
	A	B	F	C		右刀	左刀		
SVJBR/L1212F11	12	12	16	80	VBMT1102.	2373-0004	2373-1004	M2.5x8	T8
SVJBR/L1616H11	16	16	20	100	VBMT1102.	2373-0006	2373-1006		
SVJBR/L2020K11	20	20	25	125	VBMT1102.	2373-0008	2373-1008		
SVJBR/L2525M11	25	25	32	150	VBMT1102.	2373-0010	2373-1010	M4x10	T15
SVJBR/L1616H16	16	16	20	100	VBMT1604.	2373-0012	2373-1012		
SVJBR/L2020K16	20	20	25	125	VBMT1604.	2373-0014	2373-1014		
SVJBR/L2525M16	25	25	32	150	VBMT1604.	2373-0016	2373-1016		
SVJBR/L3225P16	25	32	32	170	VBMT1604.	2373-0018	2373-1018		

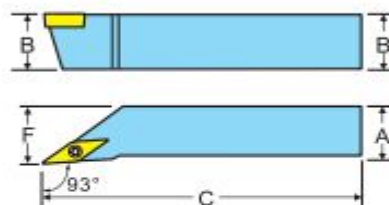

MODEL	DIMENSIONS				FOR INSERT	ITEM NO.		SCREW	WRENCH KEY
	A	B	F	C		RIGHT	LEFT		
SVJBR/L06-2J	3/8	3/8	.50	3.5	VBMT21.5.	2373-5004	2373-6004	M2.5x8	T8
SVJBR/L08-2A	1/2	1/2	.625	4	VBMT21.5.	2373-5006	2373-6006		
SVJBR/L10-2B	5/8	5/8	.75	4.5	VBMT21.5.	2373-5008	2373-6008		
SVJBR/L12-3B	3/4	3/4	1	4.5	VBMT33.	2373-5010	2373-6010	M4x10	T15
SVJBR/L16-3C	1	1	1.25	5	VBMT33.	2373-5012	2373-6012		
SVJBR/L16-3D	1	1	1.25	6	VBMT33.	2373-5014	2373-6014		





# Cutoutil

Metal Carbide Inserts, Turning Tools, Indexable Milling, Carbide Drill

www.cutoutil.com

## SVVBN 72.5° 仿形加工

型号	刀体几何尺寸				通用刀片	产品货号		螺丝	扳手
	A	B	F	C					
SVVBN1212F11	12	12	6	80	VBMT1102.	2374-0004			
SVVBN1616H11	16	16	8	100	VBMT1102.	2374-0006	M2.5x8	T8	
SVVBN2020K11	20	20	10	125	VBMT1102.	2374-0008			
SVVBN1616H16	16	16	8	100	VBMT1604.	2374-0010			
SVVBN2020K16	20	20	10	125	VBMT1604.	2374-0012	M4x10	T15	
SVVBN2525M16	25	25	12.5	150	VBMT1604.	2374-0014			

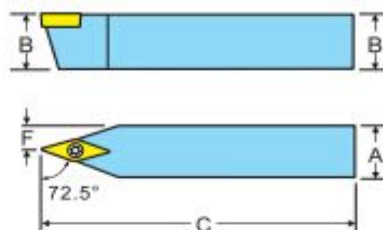

MODEL	DIMENSIONS				FOR INSERT	ITEM NO.	SCREW	WRENCH KEY
	A	B	F	C				
SVVBN06-2J	3/8	3/8	.188	3.5	VBMT21.5.	2374-5004	M2.5x8	T8
SVVBN08-2A	1/2	1/2	.25	4	VBMT21.5.	2374-5006		
SVVBN10-3B	5/8	5/8	.313	4.5	VBMT33.	2374-5008		
SVVBN12-3B	3/4	3/4	.374	4.5	VBMT33.	2374-5010	M4x10	T15
SVVBN16-3D	1	1	.50	6	VBMT33.	2374-5012		

## STGCR/L 90° 外圆加工

型号	刀体几何尺寸				通用刀片	产品货号		螺丝	扳手
	A	B	F	C		右刀	左刀		
STGCR/L0808D09	8	8	10	60	TCMT0902.	2375-0004	2375-1004	M2.2x6	T6
STGCR/L1010E09	10	10	12	70	TCMT0902.	2375-0006	2375-1006		
STGCR/L1212F11	12	12	16	80	TCMT1102.	2375-0008	2375-1008	M2.5x8	T8
STGCR/L1616H11	16	16	20	100	TCMT1102.	2375-0010	2375-1010		
STGCR/L2020K16	20	20	25	125	TCMT16T3.	2375-0012	2375-1012	M4x10	T15
STGCR/L2525M16	25	25	32	150	TCMT16T3.	2375-0014	2375-1014		

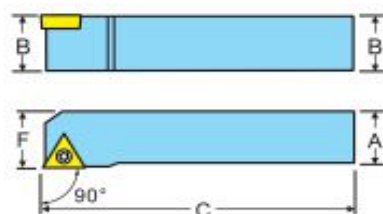

MODEL	DIMENSIONS				FOR INSERT	ITEM NO.		SCREW	WRENCH KEY
	A	B	F	C		RIGHT	LEFT		
STGCR/L06-2	3/8	3/8	.50	2.5	TCMT21.51	2375-5004	2375-6004		
STGCR/L08-2J	1/2	1/2	.625	3.5	TCMT21.51	2375-5006	2375-6006	M2.5x8	T8
STGCR/L10-2A	5/8	5/8	.75	4	TCMT21.51	2375-5008	2375-6008		
STGCR/L10-3B	5/8	5/8	.75	4.5	TCMT32.52	2375-5010	2375-6010		
STGCR/L12-3B	3/4	3/4	1.00	4.5	TCMT32.52	2375-5012	2375-6012	M4x10	T15
STGCR/L16-3D	1	1	1.25	6	TCMT32.52	2375-5014	2375-6014		





# Cutoutil

Metal Carbide Inserts, Turning Tools, Indexable Milling, Carbide Drill

www.cutoutil.com

## SVVCN 72.5° 仿形加工

型号	刀体几何尺寸				通用刀片	产品货号	螺丝 扳手	
	A	B	F	C			螺丝	扳手
SVVCN1212F11	12	12	6	80	VCMT1102.	2374-0110	M2.5x8	T8
SVVCN1616H11	16	16	8	100	VCMT1102.	2374-0112		
SVVCN2020K11	20	20	10	125	VCMT1102.	2374-0114		
SVVCN1616H16	16	16	8	100	VCMT1604.	2374-0116	M4x10	T15
SVVCN2020K16	20	20	10	125	VCMT1604.	2374-0118		
SVVCN2525M16	25	25	12.5	150	VCMT1604.	2374-0120		

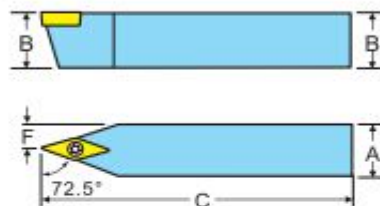

MODEL	DIMENSIONS				FOR INSERT	ITEM NO.	SCREW WRENCH KEY	
	A	B	F	C			SCREW	WRENCH KEY
SVVCN06-2J	3/8	3/8	.188	3.5	VCMT21.5.	2374-5110	M2.5x8	T8
SVVCN08-3A	1/2	1/2	.25	4	VCMT33.	2374-5112		
SVVCN10-3B	5/8	5/8	.313	4.5	VCMT33.	2374-5114	M4x10	T15
SVVCN12-3B	3/4	3/4	.925	4.5	VCMT33.	2374-5116		
SVVCN16-4D	1	1	.50	6	VCMT43.	2374-5118		

## SRDCN 90° 外圆加工

型号	刀体几何尺寸				通用刀片	产品货号	螺丝 扳手	
	A	B	F	C			螺丝	扳手
SRDCN2020K12	20	20	10	150	RCMT1204.	2376-0004	M4x10	T15
SRDCN2525M12	25	25	12.5	150	RCMT1204.	2376-0006		
SRDCN3232P16	32	32	16	170	RCMT1606.	2376-0008	M5x12	T20
SRDCN4040R16	40	40	20	200	RCMT1606.	2376-0010		
SRDCN3232P20	32	32	16	170	RCMT2006.	2376-0012	M6x15	T25
SRDCN4040R20	40	40	20	200	RCMT2006.	2376-0014		

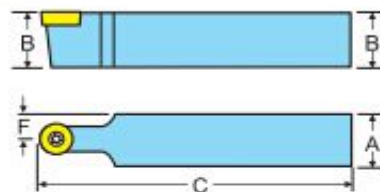

## SRGCR/L 90° 外圆, 仿形加工

型号	刀体几何尺寸				通用刀片	产品货号		螺丝 扳手	
	A	B	F	C		右刀	左刀	螺丝	扳手
SRGCR/L1616H10	16	16	20	100	RCMT10T3.	2377-0002	2377-1002	M4x10	T15
SRGCR/L2020K10	20	20	25	125	RCMT10T3.	2377-0004	2377-1004		
SRGCR/L2525M10	25	25	32	150	RCMT10T3.	2377-0006	2377-1006		
SRGCR/L2020K12	20	20	25	125	RCMT1204.	2377-0008	2377-1008		
SRGCR/L2525M12	25	25	32	150	RCMT1204.	2377-0010	2377-1010		





# Cutoutil

Metal Carbide Inserts, Turning Tools, Indexable Milling, Carbide Drill

www.cutoutil.com

## SCFCR/L 90° 端面加工

型号	刀体几何尺寸				适用刀片	产品货号		螺丝	扳手
	A	B	F	C		右刀	左刀		
SCFCR/L0808D06	8	8	10	60	CCMT0602	2370-0110	2370-1110	M2.5x8	T8
SCFCR/L1010E06	10	10	12	70	CCMT0602	2370-0112	2370-1112		
SCFCR/L1212F09	12	12	16	80	CCMT09T3	2370-0114	2370-1114	M4x10	T15
SCFCR/L1616H09	16	16	20	100	CCMT09T3	2370-0116	2370-1116		
SCFCR/L2020K09	20	20	25	125	CCMT09T3	2370-0118	2370-1118	M5x12	T20
SCFCR/L2020K12	20	20	25	125	CCMT1204	2370-0120	2370-1120		
SCFCR/L2525M12	25	25	32	150	CCMT1204	2370-0120	2370-1120		

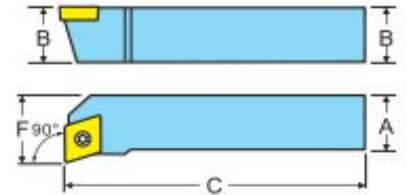

MODEL	DIMENSIONS				FOR INSERT	ITEM NO.		SCREW	WRENCH KEY
	A	B	F	C		RIGHT	LEFT		
SCFCR/L06-2J	3/8	3/8	.5	3.5	CCMT21.5	2370-5110	2370-6110	M2.5x8	T8
SCFCR/L08-3A	1/2	1/2	.625	4	CCMT32.5	2370-5112	2370-6112		
SCFCR/L10-3B	5/8	5/8	.75	4.5	CCMT32.5	2370-5114	2370-6114	M4x10	T15
SCFCR/L12-3B	3/4	3/4	1	4.5	CCMT32.5	2370-5116	2370-6116		
SCFCR/L12-4B	3/4	3/4	1	4.5	CCMT43.	2370-5118	2370-6118	M5x12	T20
SCFCR/L16-4D	1	1	1.25	6	CCMT43.	2370-5120	2370-6120		

## STFCR/L 90° 端面加工

型号	刀体几何尺寸				适用刀片	产品货号		螺丝	扳手
	A	B	F	C		右刀	左刀		
STFCR/L0808D09	8	8	10	60	TCMT0902	2375-0110	2375-1110	M2.2x6	T6
STFCR/L1010E09	10	10	12	70	TCMT0902	2375-0112	2375-1112		
STFCR/L1212F11	12	12	16	80	TCMT1102	2375-0114	2375-1114	M2.5x8	T8
STFCR/L1616H11	16	16	20	100	TCMT1102	2375-0116	2375-1116		
STFCR/L2020K16	20	20	25	125	TCMT16T3	2375-0118	2375-1118	M4x10	T15
STFCR/L2525M16	25	25	32	150	TCMT16T3	2375-0120	2375-1120		

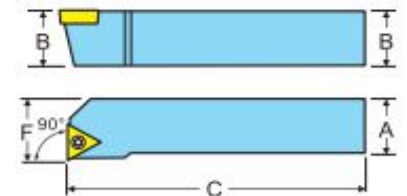

MODEL	DIMENSIONS				FOR INSERT	ITEM NO.		SCREW	WRENCH KEY
	A	B	F	C		RIGHT	LEFT		
STFCR/L06-2	3/8	3/8	.5	2.5	TCMT21.5	2375-5110	2375-6110	M2.5x8	T8
STFCR/L08-2J	1/2	1/2	.625	3.5	TCMT21.5	2375-5112	2375-6112		
STFCR/L10-2A	5/8	5/8	.75	4.0	TCMT21.5	2375-5114	2375-6114	M4x10	T15
STFCR/L10-3B	5/8	5/8	.75	4.5	TCMT32.5	2375-5116	2375-6116		
STFCR/L12-3B	3/4	3/4	1	4.5	TCMT32.5	2375-5118	2375-6118	M5x12	T20
STFCR/L16-3D	1	1	1.25	6.0	TCMT32.5	2375-5120	2375-6120		





# Cutoutil

Metal Carbide Inserts, Turning Tools, Indexable Milling, Carbide Drill

www.cutoutil.com

## QA型切断切槽车刀

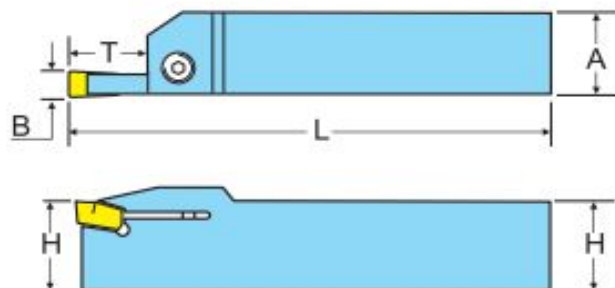

型号	刀体几何尺寸					通用刀片	产品货号		螺丝	扳手
	A	H	L	B	T		右刀	左刀		
QA1616R/L03	16	16	100	3	20	GTN-3	2415-0020	2415-1020	M5x14	S4
QA2020R/L03	20	20	125	3	20	GTN-3	2415-0022	2415-1022	M6x18	S5
QA2525R/L03	25	25	150	3	20	GTN-3	2415-0024	2415-1024		
QA3225R/L03	25	32	170	3	38	GTN-3	2415-0026	2415-1026		
QA1616R/L04	16	16	100	4	20	GTN-4	2415-0028	2415-1028	M5x14	S4
QA2020R/L04	20	20	125	4	20	GTN-4	2415-0030	2415-1030	M6x18	S5
QA2525R/L04	25	25	150	4	20	GTN-4	2415-0032	2415-1032		
QA3225R/L04	25	32	170	4	38	GTN-4	2415-0034	2415-1034		
QA2020R/L05	20	20	125	5	20	GTN-5	2415-0035	2415-1035	M6x18	S5
QA2525R/L05	25	25	150	5	32	GTN-5	2415-0036	2415-1036		
QA3225R/L05	25	32	170	5	32	GTN-5	2415-0038	2415-1038		
QA2525R/L06	25	25	150	6	32	GTN-6	2415-0040	2415-1040	M6x18	S5
QA3225R/L06	25	32	170	6	32	GTN-6	2415-0042	2415-1042		

MODEL	DIMENSIONS					FOR INSERT	ITEM NO.		SCREW	WRENCH
	A	H	L	B	T		RIGHT	LEFT		
QA08R/L-20	.500	.500	4.5	.079	.79	GTN-2	2415-5024	2415-6024	M4x10	S3
QA10R/L-20	.625	.625	4.5	.079	.79	GTN-2	2415-5026	2415-6026	M5x14	S4
QA12R/L-20	.750	.750	5.0	.079	.79	GNT-2	2415-5028	2415-6028	M6x18	S5
QA12R/L-30	.750	.750	5.0	.118	.79	GTN-3	2415-5030	2415-6030		
QA16R/L-30	1.00	1.00	6.0	.118	.79	GTN-3	2415-5032	2415-6032		
QA12R/L-40	.750	.750	5.0	.157	.98	GTN-4	2415-5034	2415-6034	M6x18	S5
QA16R/L-40	1.00	1.00	6.0	.157	.98	GTN-4	2415-5036	2415-6036		
QA20R/L-40	1.25	1.25	6.0	.157	.98	GTN-4	2415-5038	2415-6038		
QA16R/L-50	1.00	1.00	6.0	.197	1.26	GTN-5	2415-5040	2415-6040	M6x18	S5
QA20R/L-50	1.25	1.25	6.0	.197	1.26	GTN-5	2415-5042	2415-6042		
QA16R/L-60	1.00	1.00	6.0	.236	1.26	GTN-6	2415-5044	2415-6044	M6x18	S5
QA20R/L-60	1.25	1.25	6.0	.236	1.26	GTN-6	2415-5046	2415-6046		





# Cutoutil

Metal Carbide Inserts, Turning Tools, Indexable Milling, Carbide Drill

www.cutoutil.com

## 自紧式切断车刀



SLTHR/L

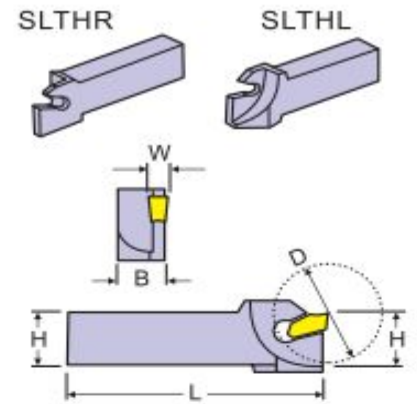

型号	刀体几何尺寸					工件最大 切削直径	适用刀片	产品货号		扳手
	W	H	B	L				右刀	左刀	
SLTHR/L10-2	2.2-2.4	10	9.5	86		28	GTN-2	2409-0002	2409-1002	CT001
SLTHR/L12-2	2.2-2.4	10	10	110		30	GTN-2	2409-0004	2409-1004	
SLTHR/L12-3	3.1	12	10	110		32	GTN-3	2409-0006	2409-1006	
SLTHR/L16-2	2.2-2.4	12	10	110		30	GTN-2	2409-0008	2409-1008	
SLTHR/L16-3	3.1	16	12	110		32	GTN-3	2409-0010	2409-1010	
SLTHR/L16-4	4.1	16	12	110		34	GTN-4	2409-0012	2409-1012	
SLTHR/L20-2	2.2-2.4	16	12	110		32	GTN-2	2409-0014	2409-1014	
SLTHR/L20-3	3.1	20	12	110		36	GTN-3	2409-0016	2409-1016	
SLTHR/L20-4	4.1	20	12	110		39	GTN-4	2409-0018	2409-1018	
SLTHR/L20-5	5.1	20	12	110		39	GTN-5	2409-0020	2409-1020	

TOOL HOLDER	DIMENSIONS					MAX.WORK DIAMETER	FOR INSERT	ITEM NO.		WRENCH
	W	H	B	L				RIGHT	LEFT	
SLTHR/L9.5-2	.087 & .094	3/8	3/8	3.38		1-7/64	GTN-2	2408-0002	2408-1002	CT001
SLTHR/L9.5-3	.120	3/8	3/8	3.38		1-7/64	GTN-3	2408-0004	2408-1004	
SLTHR/L10-2	.087 & .094	25/64	3/8	4.33		1-7/64	GTN-2	2408-0006	2408-1006	
SLTHR/L12.7-2	.087 & .094	1/2	25/64	4.33		1-11/64	GTN-2	2408-0008	2408-1008	
SLTHR/L12.7-3	.120	1/2	25/64	4.33		1-17/64	GTN-3	2408-0010	2408-1010	
SLTHR/L16-2	.087 & .094	5/8	25/64	4.33		1-11/64	GTN-2	2408-0012	2408-1012	
SLTHR/L16-3	.120	5/8	15/32	4.33		1-17/64	GTN-3	2408-0014	2408-1014	
SLTHR/L16-4	.160	5/8	15/32	4.33		1-21/64	GTN-4	2408-0016	2408-1016	
SLTHR/L19-2	.087 & .094	3/4	15/32	4.33		1-17/64	GTN-2	2408-0018	2408-1018	
SLTHR/L19-3	.120	3/4	15/32	4.33		1-13/32	GTN-3	2408-0020	2408-1020	
SLTHR/L19-4	.160	3/4	15/32	4.33		1-17/32	GTN-4	2408-0022	2408-1022	
SLTHR/L19-5	.187 & .200	3/4	15/32	4.33		1-17/32	GTN-5	2408-0024	2408-1024	
SLTHR/L25.4-3	.120	1	63/64	4.33		2-1/16	GTN-3	2408-0026	2408-1026	
SLTHR/L25.4-4	.160	1	63/64	4.33		2-1/2	GTN-4	2408-0028	2408-1028	
SLTHR/L25.4-5	.187 & .200	1	63/64	4.33		3	GTN-5	2408-0030	2408-1030	



# Cutoutil

Metal Carbide Inserts, Turning Tools, Indexable Milling, Carbide Drill

www.cutoutil.com

## 自紧式切断车刀



SGTHR/L

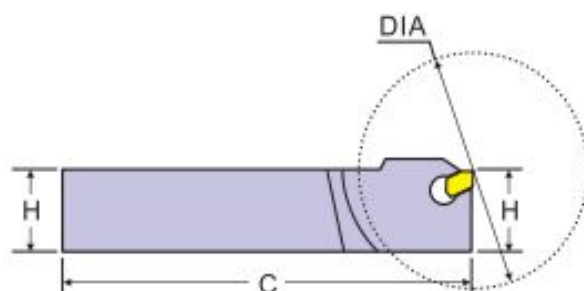

### Imperial T-Cut SGTHR/L *Not Including Inserts with "F" type*

TOOL HOLDER	INSERT WIDTH	H	B	L	MAX. WORK DIAMETER	FOR INSERT	ITEM NO.		WRENCH
							RIGHT	LEFT	
SGTHR/L 9.5-2	.087 & .094	.375	.375	3.38	1.10	GTN-2	2409-5032	2409-6032	CT001
SGTHR/L 9.5-3	.120	.375	.375	3.38	1.10	GTN-3	2409-5034	2409-6034	
SGTHR/L 12-2	.087 & .094	.472	.394	4.33	1.18	GTN-2	2409-5036	2409-6036	
SGTHR/L 12-3	.120	.472	.394	4.33	1.26	GTN-3	2409-5038	2409-6038	
SGTHR/L 12.7-2	.087 & .094	.500	.375	4.33	1.18	GTN-2	2409-5040	2409-6040	
SGTHR/L 12.7-3	.120	.500	.375	4.33	1.26	GTN-3	2409-5042	2409-6042	
SGTHR/L 16-2	.087 & .094	.625	.394	4.33	1.18	GTN-2	2409-5044	2409-6044	
SGTHR/L 16-3	.120	.625	.472	4.33	1.26	GTN-3	2409-5046	2409-6046	
SGTHR/L 16-4	.160	.625	.472	4.33	1.34	GTN-4	2409-5048	2409-6048	
SGTHR/L 19-2	.084 & .094	.750	.500	4.33	1.38	GTN-2	2409-5050	2409-6050	
SGTHR/L 19-3	.120	.750	.500	4.33	1.38	GTN-3	2409-5052	2409-6052	
SGTHR/L 19-4	.160	.750	.500	5.33	1.38	GTN-4	2409-5054	2409-6054	
SGTHR/L 19-5	.187 & .200	.750	.500	5.33	1.38	GTN-5	2409-5056	2409-6056	
SGTHR/L 25.4-3	.120	1	1	5.90	2.05	GTN-3	2409-5058	2409-6058	
SGTHR/L 25.4-4	.160	1	1	5.90	2.44	GTN-3	2409-5060	2409-6060	
SGTHR/L 25.4-5	.187 & .200	1	1	5.90	2.95	GTN-5	2409-5062	2409-6062	



# Cutoutil

Metal Carbide Inserts, Turning Tools, Indexable Milling, Carbide Drill

www.cutoutil.com

## 自紧式切断车刀



SLTBN

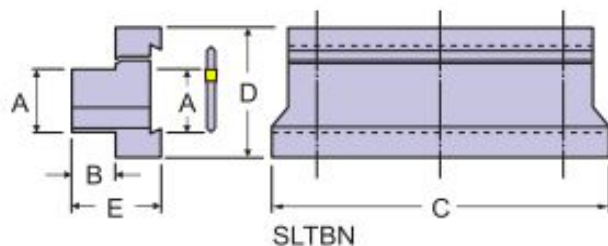

型号	配合刀粒	刀身几何尺寸					货号	扳手
		A	B	C	D	E		
SLTBN06-02	SLIH,NCIH19-2,3	6	12	56	30	25	2406-0014	CT001
SLTBN08-02	SLIH,NCIH19-2,3	8	12	56	30	25	2406-0016	
SLTBN10-02	SLIH,NCIH19-2,3	10	12	56	30	25	2406-0018	
SLTBN12-02	SLIH,NCIH19-2,3	12	12	56	30	25	2406-0020	
SLTBN16-02	SLIH,NCIH19-2,3	16	16	76	30	26	2406-0002	
SLTBN16-05	SLIH,NCIH26-2,3,4,5,6	16	16	87	38	33	2406-0004	
SLTBN20-05	SLIH,NCIH26-2,3,4,5,6	20	20	87	38	36	2406-0006	
SLTBN20-06	SLIH,NCIH32-3,4,5,6	20	20	100	48	36	2406-0008	
SLTBN25-06	SLIH,NCIH32-3,4,5,6	25	20	110	48	37	2406-0010	
SLTBN32-06	SLIH,NCIH32-3,4,5,6	32	25	110	48	46	2406-0012	

Imperial

TOOL BLOCK	ACCERTS BLADE	DIMENSIONS					WRENCH	
		A	B	C	D	E		
SLTBN1/4-2	SLIH,NCIH19-2,3	1/4	5/8	3	1-5/16	1-3/16	2405-0016	CT001
SLTBN5/16-2	SLIH,NCIH19-2,3	5/16	5/8	3	1-5/16	1-3/16	2405-0018	
SLTBN3/8-2	SLIH,NCIH19-2,3	3/8	5/8	3	1-5/16	1-3/16	2405-0020	
SLTBN1/2-2	SLIH,NCIH19-2,3	1/2	5/8	3	1-5/16	1-3/16	2405-0022	
SLTBN16-2	SLIH,NCIH19-2,3	5/8	5/8	3-7/16	1-3/16	1-1/64	2405-0002	
SLTBN16-5	SLIH,NCIH26-2,3,4,5,6	5/8	5/8	3-7/16	1-1/2	1-5/16	2405-0004	
SLTBN19-5	SLIH,NCIH26-2,3,4,5,6	3/4	3/4	3-7/16	1-1/2	1-7/16	2405-0006	
SLTBN19-6	SLIH,NCIH32-3,4,5,6	3/4	3/4	3-15/16	1-7/8	1-3/8	2405-0008	
SLTBN25-6	SLIH,NCIH32-3,4,5,6	1	25/32	4-5/16	1-7/8	1-15/32	2405-0010	
SLTBN25.4-6	SLIH,NCIH32-3,4,5,6	1	7/8	4-1/2	1-7/8	1-17/32	2405-0012	
SLTBN32-6	SLIH,NCIH32-3,4,5,6	1-1/4	1-1/8	4-5/16	1-7/8	1-13/16	2405-0014	





# Cutoutil

Metal Carbide Inserts, Turning Tools, Indexable Milling, Carbide Drill

www.cutoutil.com

## 切刀板 SLIH



英制

BLADE #	INSERT WIDTH	MAX.WORK DIAMETER	MAX.WORK				ORDER #	KEY
			A	L	H1	H		
SLIH19-2	.087 & .094	1-1/2	.063	3.38	.62	.75	2401-0002	CT001
SLIH26-2	.087 & .094	3	.063	4.33	.84	1.02	2401-0004	
SLIH26-3	.120	3	.094	4.33	.84	1.02	2401-0006	
SLIH26-4	.160	3	.125	4.33	.84	1.02	2401-0008	
SLIH26-5	.187 & .200	4	.156	4.33	.84	1.02	2401-0010	
SLIH26-6	.250	4	.203	4.33	.84	1.05	2401-0012	
SLIH32-3	.120	4	.094	5.90	.98	1.25	2401-0014	
SLIH32-4	.160	4	.125	5.90	.98	1.25	2401-0016	
SLIH32-5	.187 & .200	5	.156	5.90	.98	1.25	2401-0018	
SLIH32-6	.250	5	.203	5.90	.98	1.25	2401-0020	

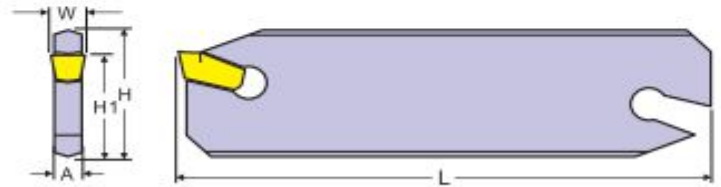

## 切刀板 NCIH



英制

BLADE #	INSERT WIDTH	MAX.WORK DIAMETER	MAX.WORK				ITEM NO	KEY
			A	L	H1	H		
NCIH19-2	.087 & .094	1-1/2	.063	3.38	.62	.75	2402-0002	CT001
NCIH26-2	.087 & .094	3	.063	4.33	.84	1.02	2402-0004	
NCIH26-3	.120	3	.094	4.33	.84	1.02	2402-0006	
NCIH26-4	.160	3	.125	4.33	.84	1.02	2402-0008	
NCIH26-5	.187 & .200	4	.156	4.33	.84	1.02	2402-0010	
NCIH26-6	.250	4	.203	4.33	.84	1.05	2402-0012	
NCIH32-3	.120	4	.094	5.90	.98	1.25	2402-0014	
NCIH32-4	.160	4	.125	5.90	.98	1.25	2402-0016	
NCIH32-5	.187 & .200	5	.156	5.90	.98	1.25	2402-0018	
NCIH32-6	.250	5	.203	5.90	.98	1.25	2402-0020	

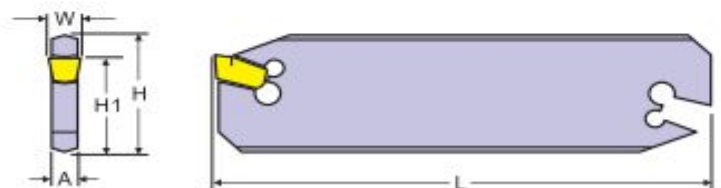



# Cutoutil

Metal Carbide Inserts, Turning Tools, Indexable Milling, Carbide Drill

www.cutoutil.com

## 外径、切槽车刀

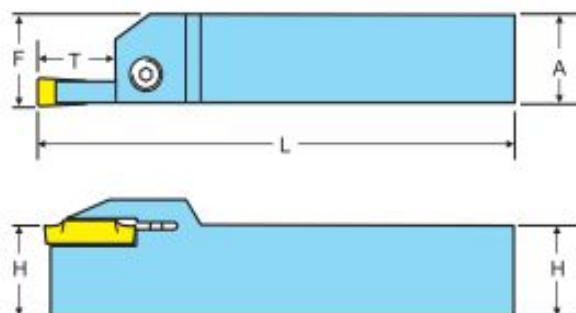

MGEHR/L

型号	A	H	L	F	T	通用刀片	货号		螺丝	扳手
							左刀	右刀		
MGEHR/L0808E02	8	8	70	8.25	14.5	MGMN200	2413-0034	2413-1034	GB70-85-M4X12	S3
MGEHR/L1010E02	10	10	70	10.25	14.5	MGMN200	2413-0036	2413-1036		
MGEHR/L1212H02	12	12	100	12.25	14.5	MGMN200	2413-0038	2413-1038		
MGEHR/L1616H02	16	16	100	16.25	14.5	MGMN200	2413-0002	2413-1002		
MGEHR/L2020K02	20	20	125	20.25	14.5	MGMN200	2413-0004	2413-1004		
MGEHR/L2525M02	25	25	150	25.25	14.5	MGMN200	2413-0006	2413-1006		
MGEHR/L1616H03	16	16	100	16.35	18.5	MGMN300	2413-0008	2413-1008	GB70-85-M5X14	S4
MGEHR/L2020K03	20	20	125	20.4	18	MGMN300	2413-0010	2413-1010		
MGEHR/L2525M03	25	25	150	25.4	18	MGMN300	2413-0012	2413-1012		
MGEHR/L3232P03	32	32	170	32.4	18	MGMN300	2413-0014	2413-1014		
MGEHR/L2020K04	20	20	125	20.4	18	MGMN400	2413-0016	2413-1016	GB70-85-M6x20	S5
MGEHR/L2525M04	25	25	150	25.4	18	MGMN400	2413-0018	2413-1018		
MGEHR/L3232P04	32	32	170	32.4	18	MGMN400	2413-0020	2413-1020		
MGEHR/L2020K05	20	20	125	20.5	23	MGMN500	2413-0022	2413-1022		
MGEHR/L2525M05	25	25	150	25.4	23	MGMN500	2413-0024	2413-1024		
MGEHR/L3232P05	32	32	170	32.4	23	MGMN500	2413-0026	2413-1026		
MGEHR/L2020K06	20	20	125	20.6	23	MGMN600	2413-0028	2413-1028		
MGEHR/L2525M06	25	25	150	25.6	23	MGMN600	2413-0030	2413-1030		
MGEHR/L3232P06	32	32	170	32.6	23	MGMN600	2413-0032	2413-1032		



# Cutoutil

Metal Carbide Inserts, Turning Tools, Indexable Milling, Carbide Drill

www.cutoutil.com

## 内径、切槽车刀

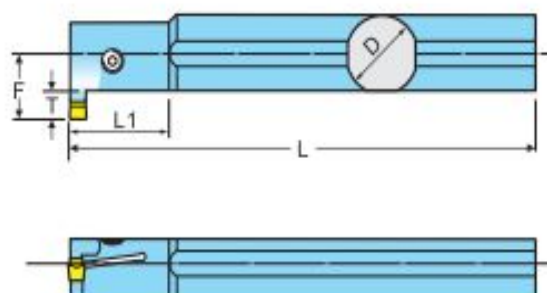

S-MGEHR/L

型号	D	L	L1	F	T	最小加工直径	适用刀片	货号		螺丝	扳手
								左刀	右刀		
S16K-MGIVR/L02	16	125	35	12.4	5	20	MGMN1.5	2413-5002	2413-6002	GB70-85-M4x10	S3
S20M-MGIVR/L02	20	150	45	14	5	25	MGNM1.5	2413-5004	2413-6004	GB70-85-M5x15	S4
S25R-MGIVR/L02	25	200	45	17.2	5	29	MGNM1.5	2413-5006	2413-6006		
S20M-MGIVR/L03	20	150	45	15.6	6	25	MGNM2.0	2413-5008	2413-6008		
S25R-MGIVR/L03	25	200	45	18.9	6	31	MGNM2.5	2413-5010	2413-6010		
S32S-MGIVR/L03	32	250	65	21.5	6	37	MGNM2.5	2413-5012	2413-6012		
S20M-MGIVR/L04	20	150	45	15.6	6	25	MGNM2.5	2413-5014	2413-6014		
S25R-MGIVR/L04	25	200	45	18.9	6	31	MGNM3.0	2413-5016	2413-6016		
S32S-MGIVR/L04	32	250	65	21.5	6	37	MGNM3.0	2413-5018	2413-6018		
S25R-MGIVR/L05	25	200	45	19.4	8	31	MGNM3.0	2413-5020	2413-6020		
S32S-MGIVR/L05	32	250	65	21.5	8	37	MGNM4.0	2413-5022	2413-6022		
S25R-MGIVR/L06	25	200	45	19.4	8	31	MGNM4.0	2413-5024	2413-6024		
S32S-MGIVR/L06	32	250	65	21.5	8	37	MGNM4.0	2413-5026	2413-6026		





# Cutoutil

Metal Carbide Inserts, Turning Tools, Indexable Milling, Carbide Drill

www.cutoutil.com

## 立装外螺纹车刀



MTHR/L MTVOR/L

型号	刀体几何尺寸				适用刀片	产品货号		刀片螺钉	压板	弹簧	压板螺丝	扳手
	A	B	F	C		右刀	左刀					
MTHR/L1616H4	16	16	16	100	22VER	2654-4010	2654-5010	M4x12	MTH0820 MTH0820z	MTH0610	MTH0623	T15 S4
MTHR/L2020K4	20	20	20	125	22VER	2654-4002	2654-5002					
MTHR/L2520M4	25	20	25	150	22VER	2654-4004	2654-5004					
MTHR/L3225P4	32	25	25	170	22VER	2654-4006	2654-5006					
MTHR/L3232P4	32	32	32	170	22VER	2654-4008	2654-5008					

MODEL	DIMENSIONS				INSERT	ITEM NO.		SCREW	CLAMP	SPRING	SCREW	WRENCH
	A	B	F	C		RIGHT	LEFT					
MTVOR/L08-3B	0.5	0.5		4.5	16VER	2654-0012	2654-1012	M3.5x8	MTH0820 MTH0820z	MTH0610	MTH0623	T15 S4
MTVOR/L10-3B	.625	.625	.75	4.5	16VER	2654-0002	2654-1002					
MTVOR/L12-3B	.75	.75	.75	4.5	16VER	2654-0004	2654-1004					
MTVOR/L16-3D	1.00	1.00	1.00	6.0	16VER	2654-0006	2654-1006	M4x12	MTH0820 MTH0820z	MTH0610	MTH0623	T15 S4
MTVOR/L12-4B	.75	.75	.75	4.5	22VER	2654-0008	2654-1008					
MTVOR/L16-4D	1.00	1.00	1.00	6.0	22VER	2654-0010	2654-1010					

## 刀片 INSERTS

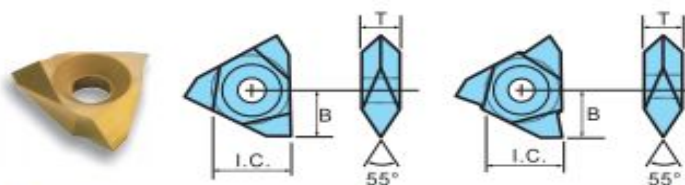

Tin-Coated

MODEL #	I.C.	B	T	55°		60°	
				ORDER #	ORDER #	ORDER #	ORDER #
16VER	3/8	.306	.125	2654-0300	2654-1300	2654-0301	2654-1301
22VER	1/2	.415	.187	-	-	2654-0302	2654-1302



# Cutoutil

Metal Carbide Inserts, Turning Tools, Indexable Milling, Carbide Drill

www.cutoutil.com

## 平装外螺纹车刀



SER/L

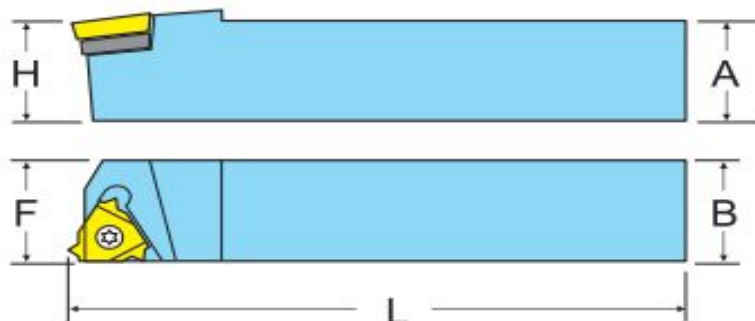

型号	A	B	F	L	适用刀片	货号	刀垫	刀垫螺钉	压紧螺钉	扳手
SER1212H11	12	12	15	100	11ER..	2651-1001	LT16R-3.0	SDN535	M2.5x6	T8
SER1616H16	16	16	16	100	16ER..	2651-1003				
SER2020K16	20	20	20	125	16ER..	2651-1005				
SER2525M16	25	25	25	150	16ER..	2651-1007				
SER3225P16	32	25	25	170	16ER..	2651-1009				
SEL1212H11	12	12	15	100	11EL..	2651-2001	LT16L-3.0	SDN535	M2.5x6	T8
SEL1616H16	16	16	16	100	16EL..	2651-2003				
SEL2020K16	20	20	20	125	16EL..	2651-2005				
SEL2525M16	25	25	25	150	16EL..	2651-2007				
SEL3225P16	32	25	25	170	16EL..	2651-2009				

MODEL	A	B	F	L	INSERT	ITEM NO.	SHIM	SHIM PIN	SCREW	WRENCH
SER0375F11	.38	.38	.50	3.25	11ER..	2651-0001	LT16R-3.0	SDN535	M2.5x6	T8
SER0500H11	.50	.50	.50	4.00	16ER..	2651-0003				
SER0625K16	.63	.63	.63	5.00	16ER..	2651-0005				
SER0750K16	.75	.75	.75	5.00	16ER..	2651-0007				
SER1000M16	1.0	1.0	1.0	6.00	16ER..	2651-0009				
SEL0375F11	.38	.38	.50	3.25	11EL..	2651-3001	LT16L-3.0	SDN535	M2.5x6	T8
SEL0500H11	.50	.50	.50	4.00	16EL..	2651-3003				
SEL0625K16	.63	.63	.63	5.00	16EL..	2651-3005				
SEL0750K16	.75	.75	.75	5.00	16EL..	2651-3007				
SEL1000M16	1.0	1.0	1.0	6.00	16EL..	2651-3009				

## 平装螺纹车刀零件

刀片安装螺钉



规格	刀片	货号
MLD-M25	11ER	2995-0162
MLD-M35	16ER	2995-0163
MLD-M50	22ER	2995-0166

刀垫紧固螺钉



规格	刀片	货号
SDN535	16ER	2995-0300
SDN850	22ER	2995-0302

刀垫



规格	刀片	货号
LT16R-3.0	16ER	2995-0400
LT16L-3.0	16IR	2995-0402
LT22R-4.0	22ER	2995-0401
LT22L-4.0	22IR	2995-0403







# Cutoutil

Metal Carbide Inserts, Turning Tools, Indexable Milling, Carbide Drill

www.cutoutil.com

## 平装内螺纹车刀

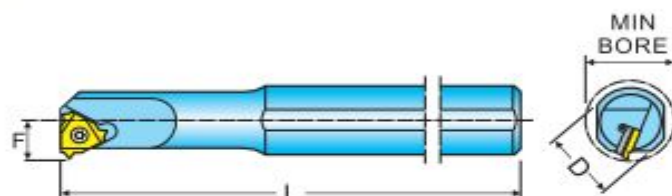

S-THSNR/L

型号	刀体几何尺寸				适用刀片	产品货号	刀垫	刀垫螺钉	压紧螺钉	扳手
	D	L	F	MIN BORE						
S10K-THSNR11	10	125	7.4	12	11NR..	2655-0001	/	/	M2.5x8	T8
S12M-THSNR11	12	150	8.5	15	11NR..	2655-0003	/	/	M2.5x8	T8
S12M-THSNR16	12	150	8.5	15	16NR..	2655-0005	/	/	M3.5x8	T15
S16M-THSNR16	16	150	10.3	19	16NR..	2655-0007	/	/	M3.5x8	T15
S20P-THSNR16	20	170	13.8	24	16NR..	2655-0009	/	/	M3.5x8	T15
S25R-THSNR16	25	200	16.3	29	16NR..	2655-0011	LT16L-3.0	SDN535	M3.5x13	T15+S3.5
S32S-THSNR16	32	250	19.8	37	16NR..	2655-0013	/	/	M3.5x13	T15+S3.5
S10K-THSNL11	10	125	7.4	12	11NL..	2655-0015	/	/	M2.5x8	T8
S12M-THSNL11	12	150	8.5	15	11NL..	2655-0017	/	/	M2.5x8	T8
S12M-THSNL16	12	150	8.5	15	16NL..	2655-0019	/	/	M3.5x8	T15
S16M-THSNL16	16	150	10.3	19	16NL..	2655-0021	/	/	M3.5x8	T15
S20P-THSNL16	20	170	13.8	24	16NL..	2655-0023	/	/	M3.5x8	T15
S25R-THSNL16	25	200	16.3	29	16NL..	2655-0025	LT16R-3.0	SDN535	M3.5x13	T15+S3.5
S32S-THSNL16	32	250	19.8	37	16NL..	2655-0027	/	/	M3.5x13	T15+S3.5

MODEL	刀体几何尺寸				INSERT	ITEM NO.	SHIM	SHIM PIN	SCREW	WRENCH
	D	L	F	MIN BORE						
SIR0375H11	.375	4.0	.29	.47	11NR..	2655-2001	/	/	M2.5x8	T8
SIR0500K11	.500	5.0	.39	.64	11NR..	2655-2003	/	/	M2.5x8	T8
SIR0625M16	.625	6.0	.45	.75	16NR..	2655-2005	/	/	M3.5x8	T15
SIR0750P16	.75	7.0	.51	1.00	16NR..	2655-2007	/	/	M3.5x8	T15
SIR1000R16	1.00	8.0	.65	1.20	16NR..	2655-2009	/	/	M3.5x8	T15
SIR1250S16	1.25	10.0	.77	1.42	16NR..	2655-2011	LT16L-3.0	SDN535	M3.5x13	T15+S3.5
SIR1500T16	1.50	12.0	.90	1.65	16NR..	2655-2013	/	/	M3.5x13	T15+S3.5
SIL0375H11	.375	4.0	.29	.47	11NL..	2655-2015	/	/	M2.5x8	T8
SIL0500K11	.500	5.0	.39	.64	11NL..	2655-2017	/	/	M2.5x8	T8
SIL0625M16	.625	6.0	.45	.75	16NL..	2655-2019	/	/	M3.5x8	T15
SIL0750P16	.75	7.0	.51	1.00	16NL..	2655-2021	/	/	M3.5x8	T15
SIL1000R16	1.00	8.0	.65	1.20	16NL..	2655-2023	/	/	M3.5x8	T15
SIL1250S16	1.25	10.0	.77	1.42	16NL..	2655-2025	LT16R-3.0	SDN535	M3.5x13	T15+S3.5
SIL1500T16	1.50	12.0	.90	1.65	16NL..	2655-2027	/	/	M3.5x13	T15+S3.5





# Cutoutil

Metal Carbide Inserts, Turning Tools, Indexable Milling, Carbide Drill

www.cutoutil.com

## 平装压板式外螺纹车刀



THCER/L

型号	A	B	F	L	适用刀片	货号	刀垫	刀垫螺钉	压板	压板螺钉	扳手卡圆
THCER1616H16	16	16	16	100	16ER..	2656-0002	LT16R-3.0		CL16TH		
THCER2020K16	20	20	20	125	16ER..	2656-0004					
THCER2525M16	25	25	25	150	16ER..	2656-0006					
THCER3225P16	25	32	25	170	16ER..	2656-0008					
THCER2525M22	25	25	25	150	22ER..	2656-0010	LT22R-4.0		CL22TH		
THCER3225P22	25	32	25	170	22ER..	2656-0012					
THCEL1616H16	16	16	16	100	16EL..	2656-0014	LT16L-3.0	LTM5x8		CLSZ	S3 E3
THCEL2020K16	20	20	20	125	16EL..	2656-0016					
THCEL2525M16	25	25	25	150	16EL..	2656-0018					
THCEL3225P16	25	32	25	170	16EL..	2656-0020					
THCEL2525M22	25	25	25	150	22EL..	2656-0022	LT22L-4.0		CL22TH		
THCEL3225P22	25	32	25	170	22EL..	2656-0024					

MODEL	A	B	F	L	INSERT	ITEM NO.	SHIM	SHIM PIN	CLAMP	CLAMP SCREW	WRENCH
THCER0625K16	.63	.63	.63	5.0	16ER..	2656-0050	LT16R-3.0		CL16TH		
THCER0750K16	.75	.75	.75	5.0	16ER..	2656-0052					
THCER1000M16	1.00	1.00	1.00	6.0	16ER..	2656-0054	LT22R-4.0		CL22TH		
THCER1000M22	1.00	1.00	1.00	6.0	22ER..	2656-0056					
THCER1250P22	1.25	1.25	1.25	7.0	22ER..	2656-0058	LT16L-3.0	LTM5x8	CL16TH	CLSZ	S3 E3
THCER0625K16	.63	.63	.63	5.0	16ER..	2656-0060					
THCEL0750K16	.75	.75	.75	5.0	16EL..	2656-0062					
THCEL1000M16	1.00	1.00	1.00	6.0	16EL..	2656-0064					
THCEL1000M22	1.00	1.00	1.00	6.0	22EL..	2656-0066	LT22L-4.0		CL22TH		
THCEL1250P22	1.25	1.25	1.25	7.0	22EL..	2656-0068					

## 平装螺纹车刀零件

上压式螺纹刀压板螺钉



型号: CLSZ

货号: 2995 - 0180

卡圈

型号: E3

货号: 2995 - 0183

上压式螺纹刀压板



型号 货号  
CL16TH 2995-0216  
CL22TH 2995-0222



# Cutoutil

Metal Carbide Inserts, Turning Tools, Indexable Milling, Carbide Drill

www.cutoutil.com

## 平装压板式内螺纹车刀



S-THCNR/L

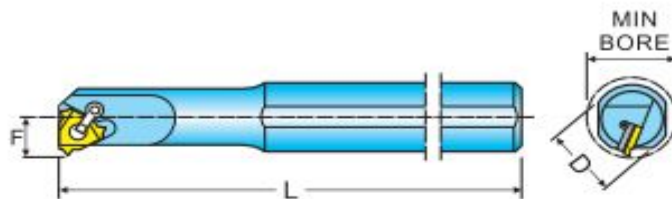

型号	刀体几何尺寸				适用刀片	产品货号	刀垫	刀垫螺钉	压板	压板螺钉	顺手卡圈
	D	L	F	最小孔径							
S20P-THCNR16	20	170	13.7	24	16NR..	2656-0080	LT16L-3.0	LTM5x8	CL16TH	CLSZ	E3 S3
S25R-THCNR16	25	200	16.3	29	16NR..	2656-0081					
S32S-THCNR16	32	250	19.8	37	16NR..	2656-0082					
S40T-THCNR16	40	300	23.8	45	16NR..	2656-0083	LT22L-4.0	LTM5x8	CL22TH	CLSZ	E3 S3
S32S-THCNR22	32	250	19.8	37	22NR..	2656-0084					
S40T-THCNR22	40	300	23.8	45	22NR..	2656-0085					
S50T-THCNR22	50	300	28.8	55	22NR..	2656-0086	LT16R-3.0	LTM5x8	CL16TH	CLSZ	E3 S3
S20P-THCNL16	20	170	13.7	24	16NL..	2656-0087					
S25R-THCNL16	25	200	16.3	29	16NL..	2656-0088					
S32S-THCNL16	32	250	19.8	37	16NL..	2656-0089	LT22R-4.0	LTM5x8	CL22TH	CLSZ	E3 S3
S40T-THCNL16	40	300	23.8	45	16NL..	2656-0090					
S32S-THCNL22	32	250	19.8	37	22NL..	2656-0091					
S40T-THCNL22	40	300	23.8	45	22NL..	2656-0092					
S50T-THCNL22	50	300	28.8	55	22NL..	2656-0093					

MODEL	D	L	F	MIN BORE	INSERT	ITEM NO.	SHIM	SHIM PIN	CLAMP	CLAMP SCREW	WRENCH
CNR0750P16	.75	7.0	.51	1.00	16NR..	2655-1080	LT16L-3.0	LTM5x8	CL16TH	CLSZ	E3 S3
CNR1000R16	1.00	8.0	.65	1.20	16NR..	2655-1081					
CNR1250S16	1.25	10.0	.77	1.42	16NR..	2655-1082					
CNR1500T16	1.50	12.0	.90	1.65	16NR..	2655-1083	LT16R-3.0	LTM5x8	CL16TH	CLSZ	E3 S3
CNL0750P16	.75	7.0	.51	1.00	16NL..	2655-1084					
CNL1000R16	1.00	8.0	.65	1.20	16NL..	2655-1085					
CNL1250S16	1.25	10.0	.77	1.42	16NL..	2655-1086					
CNL1500T16	1.50	12.0	.90	1.65	16NL..	2655-1087					





# Cutoutil

Metal Carbide Inserts, Turning Tools, Indexable Milling, Carbide Drill

www.cutoutil.com

## S-SCFCR/L 90°内孔镗刀

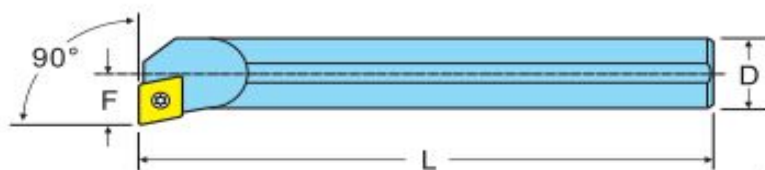
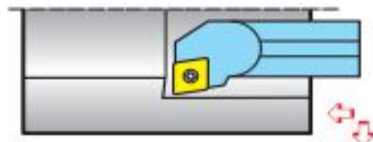

### S-SCFCR/L

型号 #	刀体几何尺寸				刀片	货号		刀垫	刀片螺钉	扳手
	D	F	L	最小镗孔		左刀	右刀			
S10K-SCFCR/L06	10	7	125	13	CCMT0602.	2600-2008	2600-3008	-	M2.5x6	T8
S12M-SCFCR/L06	12	9	150	16	CCMT0602.	2600-2010	2600-3010	-	M2.5x8	T8
S16R-SCFCR/L09	16	11	200	20	CCMT09T3.	2600-2012	2600-3012	-	M4x8	T15
S20S-SCFCR/L09	20	13	250	25	CCMT09T3.	2600-2014	2600-3014	-	M4x10	T15
S25T-SCFCR/L12	25	17	300	32	CCMT1204.	2600-2016	2600-3016	-	M4x10	T15
S32U-SCFCR/L12	32	22	350	40	CCMT1204.	2600-2018	2600-3018	-	M5x12	T20
S40U-SCFCR/L12	40	27	350	50	CCMT1204.	2600-2020	2600-3020	-	M5x12	T20

英制

MODEL #	DIMENSIONS				INSERT SIZE	ITEM NO.		SHIM	SCREW	WRENCH KEY
	D	F	L	MIN BORE		RIGHT	LEFT			
S06M-SCFCR/L2	.375	.250	6.0	.500	CCMT21.51	2600-8008	2600-9008	-	M2.5x6	T8
S08Q-SCFCR/L2	.500	.312	7.0	.625	CCMT21.51	2600-8010	2600-9010	-	M2.5x8	T8
S10R-SCFCR/L3	.625	.406	8.0	.812	CCMT32.52	2600-8012	2600-8012	-	M4x8	T15
S12S-SCFCR/L3	.750	.500	10.0	1.00	CCMT32.52	2600-8014	2600-8014	-	M4x10	T15

### A-SCFCR/L(带内冷却孔)

型号 #	刀体几何尺寸				刀片	货号		刀垫	刀片螺钉	扳手
	D	F	L	最小镗孔		左刀	右刀			
A12K-SCFCR/L06	12	9	125	16	CCMT0602.	2600-0001	2600-0002	-	M2.5x8	T8
A16M-SCFCR/L09	16	11	150	20	CCMT09T3.	2600-0003	2600-0004	-	M4x8	T15
A20Q-SCFCR/L09	20	13	180	25	CCMT09T3.	2600-0005	2600-0006	-	M4x10	T15
A25R-SCFCR/L12	25	17	200	32	CCMT1204.	2600-0007	2600-0008	-	M4x10	T15
A32S-SCFCR/L12	32	22	250	40	CCMT1204.	2600-0009	2600-0010	-	M5x12	T20
A40T-SCFCR/L12	40	27	300	50	CCMT1204.	2600-0011	2600-0012	-	M5x12	T20

英制

MODEL #	DIMENSIONS				INSERT SIZE	ITEM NO.		SHIM	SCREW	WRENCH KEY
	D	F	L	MIN BORE		RIGHT	LEFT			
A06J-SCFCR/L2	.375	.250	4.5	.500	CCMT21.51	2600-5001	2600-5002	-	M2.5x6	T8
A08M-SCFCR/L2	.500	.312	6.0	.625	CCMT21.51	2600-5003	2600-5004	-	M2.5x8	T8
A10Q-SCFCR/L3	.625	.406	7.0	.812	CCMT32.52	2600-5005	2600-5006	-	M4x8	T15
A12R-SCFCR/L3	.750	.500	8.0	1.00	CCMT32.52	2600-5007	2600-5008	-	M4x10	T15





# Cutoutil

Metal Carbide Inserts, Turning Tools, Indexable Milling, Carbide Drill

www.cutoutil.com

## S-SCLCR/L 95°内孔镗刀

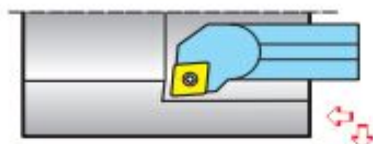

### S-SCLCR/L

型号 #	刀体几何尺寸				刀片	货号		刀垫	刀片螺钉	扳手
	D	F	L	最小镗孔		左刀	右刀			
S08H-SCLCR/L06	8	6	100	11	CCMT0602.	2601-2006	2601-3006	-	M2.5x6	T8
S10K-SCLCR/L06	10	7	125	13	CCMT0602.	2601-2008	2601-3008	-	M2.5x8	T8
S12M-SCLCR/L06	12	9	150	16	CCMT0602.	2601-2010	2601-3010	-	M2.5x8	T8
S16R-SCLCR/L09	16	11	200	20	CCMT09T3.	2601-2012	2601-3012	-	M4x8	T15
S20S-SCLCR/L09	20	13	250	25	CCMT09T3.	2601-2014	2601-3014	-	M4x10	T15
S25T-SCLCR/L12	25	17	300	32	CCMT1204.	2601-2016	2601-3016	-	M5x12	T20
S32U-SCLCR/L12	32	22	350	40	CCMT1204.	2601-2018	2601-3018	-	M5x12	T20
S40U-SCLCR/L12	40	27	350	50	CCMT1204.	2601-2020	2601-3020	-	M5x12	T20

英制

MODEL #	DIMENSIONS				INSERT SIZE	ITEM NO.		SHIM	SCREW	WRENCH KEY
	D	F	L	MIN BORE		RIGHT	LEFT			
S05H-SCLCR/L2	.3125	.250	4.0	.4375	CCMT21.51	2601-8006	2601-9006	-	M2.5x6	T8
S06M-SCLCR/L2	.375	.250	6.0	.500	CCMT21.51	2601-8008	2601-9008	-	M2.5x8	T8
S08Q-SCLCR/L2	.500	.312	7.0	.625	CCMT21.51	2601-8010	2601-9010	-	M2.5x8	T8
S10R-SCLCR/L3	.625	.406	8.0	.812	CCMT32.52	2601-8012	2601-9012	-	M4x8	T15
S12S-SCLCR/L3	.750	.500	10.0	1.00	CCMT32.52	2601-8014	2601-9014	-	M4x10	T15
S16T-SCLCR/L4	1.00	.651	12.0	1.25	CCMT432	2601-8016	2601-9016	-	M5x12	T20
S20U-SCLCR/L4	1.25	.875	14.0	1.50	CCMT432	2601-8018	2601-9018	-	M5x12	T20
S24U-SCLCR/L4	1.50	1.062	14.0	2.00	CCMT432	2601-8020	2601-9020	-	M5x12	T20

### A-SCLCR/L(带内冷却孔)

型号 #	刀体几何尺寸				刀片	货号		刀垫	刀片螺钉	扳手
	D	F	L	最小镗孔		左刀	右刀			
A12K-SCLCR/L06	12	9	125	16	CCMT0602.	2601-0001	2601-0002	-	M2.5x8	T8
A16M-SCLCR/L09	16	11	150	20	CCMT09T3.	2601-0003	2601-0004	-	M4x8	T15
A20Q-SCLCR/L09	20	13	180	25	CCMT09T3.	2601-0005	2601-0006	-	M4x10	T15
A25R-SCLCR/L12	25	17	200	32	CCMT1204.	2601-0007	2601-0008	-	M5x12	T20
A32S-SCLCR/L12	32	22	250	40	CCMT1204.	2601-0009	2601-0010	-	M5x12	T20
A40T-SCLCR/L12	40	27	300	50	CCMT1204.	2601-0011	2601-0012	-	M5x12	T20

英制

MODEL #	DIMENSIONS				INSERT SIZE	ITEM NO.		SHIM	SCREW	WRENCH KEY
	D	F	L	MIN BORE		RIGHT	LEFT			
A06J-SCLCR/L2	.375	.250	4.5	.500	CCMT21.51	2601-5001	2601-5001	-	M2.5x6	T8
A08M-SCLCR/L2	.50	.312	6.0	.625	CCMT21.51	2601-5003	2601-5003	-	M2.5x8	T8
A10Q-SCLCR/L3	.625	.406	7.0	.812	CCMT32.52	2601-5005	2601-5005	-	M4x8	T15
A12R-SCLCR/L3	.75	.500	8.0	1.00	CCMT32.52	2601-5007	2601-5007	-	M4x10	T15
A16S-SCLCR/L3	1.00	.651	10.0	1.25	CCMT432	2601-5009	2601-5009	-	M5x12	T20
A20T-SCLCR/L4	1.25	.875	12.0	1.50	CCMT432	2601-5011	2601-5011	-	M5x12	T20
A24T-SCLCR/L4	1.50	1.062	12.0	2.00	CCMT432	2601-5013	2601-5013	-	M5x12	T20



# Cutoutil

Metal Carbide Inserts, Turning Tools, Indexable Milling, Carbide Drill

www.cutoutil.com

## S-SDQCR/L 107.5°内孔镗刀

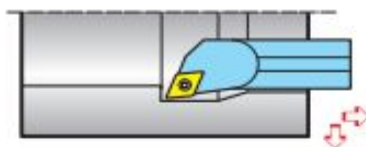

### S-SDQCR/L

型号 #	刀体几何尺寸				刀片	货号		刀垫	刀片螺钉	扳手
	D	F	L	最小镗孔		左刀	右刀			
S08H-SDQCR/L07	8	6	100	11	DCMT0702.	2602-0006	2602-1006	-	M2.5x6	
S10K-SDQCR/L07	10	7	125	13	DCMT0702.	2602-0008	2602-1008	-	M2.5x6	T8
S12M-SDQCR/L07	12	9	150	16	DCMT0702.	2602-0010	2602-1010	-	M2.5x8	
S16R-SDQCR/L07	16	11	200	20	DCMT0702.	2602-0012	2602-1012	-	M2.5x8	
S20S-SDQCR/L11	20	13	250	25	DCMT11T3.	2602-0014	2602-1014	-	M4x10	T15
S25T-SDQCR/L11	25	17	300	32	DCMT11T3.	2602-0016	2602-1016	-	M4x10	T15
S32U-SDQCR/L11	32	22	350	40	DCMT11T3.	2602-0018	2602-1018	-	M4x10	T15
S40U-SDQCR/L11	40	27	350	50	DCMT11T3.	2602-0020	2602-1020	-	M4x10	T15
S50V-SDQCR/L11	50	35	400	63	DCMT11T3.	2602-0022	2602-1022	-	M4x10	T15

英制

MODEL #	DIMENSIONS				INSERT SIZE	ITEM NO.		SHIM	SCREW	WRENCH KEY
	D	F	L	MIN BORE		RIGHT	LEFT			
S05H-SDQCR/L2	.3125	.25	4.0	.4375	DCMT21.51	2602-6006	2602-7006	-	M2.5x6	T8
S06M-SDQCR/L2	.375	.28	6.0	.50	DCMT21.51	2602-6008	2602-7008	-	M2.5x6	T8
S08Q-SDQCR/L2	.50	.375	7.0	.625	DCMT21.51	2602-6010	2602-7010	-	M2.5x8	
S10R-SDQCR/L3	.625	.4375	8.0	.75	DCMT32.52	2602-6012	2602-7012	-	M4x8	
S12S-SDQCR/L3	.75	.50	10.0	1.00	DCMT32.52	2602-6014	2602-7014	-	M4x8	
S16T-SDQCR/L3	1.00	.651	12.0	1.25	DCMT32.52	2602-6016	2602-7016	-	M4x10	T15
S20U-SDQCR/L3	1.25	.875	14.0	1.50	DCMT32.52	2602-6018	2602-7018	-	M4x10	T15
S24U-SDQCR/L3	1.5	1.062	14.0	2.00	DCMT32.52	2602-6020	2602-7020	-	M4x10	T15

### A-SDQCR/L (带内冷却)

型号 #	刀体几何尺寸				刀片	货号		刀垫	刀片螺钉	扳手
	D	F	L	最小镗孔		左刀	右刀			
A12K-SDQCR/L07	12	9	125	16	DCMT0702.	2602-5006	2602-6006	-	M2.5x8	T8
A16M-SDQCR/L07	16	11	150	20	DCMT0702.	2602-5008	2602-6008	-	M2.5x8	T8
A20Q-SDQCR/L11	20	13	180	25	DCMT11T3.	2602-5010	2602-6010	-	M4x10	T15
A25R-SDQCR/L11	25	17	200	32	DCMT11T3.	2602-5012	2602-6012	-	M4x10	T15
A32S-SDQCR/L11	32	22	250	40	DCMT11T3.	2602-5014	2602-6014	-	M4x10	T15
A40T-SDQCR/L11	40	27	300	50	DCMT11T3.	2602-5016	2602-6016	-	M4x10	T15

英制

MODEL #	DIMENSIONS				INSERT SIZE	ITEM NO.		SHIM	SCREW	WRENCH KEY
	D	F	L	MIN BORE		RIGHT	LEFT			
A06J-SDQCR/L2	.375	.25	4.5	.50	DCMT21.51	2602-5051	2602-5052	-	M2.5x6	
A08M-SDQCR/L2	.50	.312	6.0	.625	DCMT21.51	2602-5053	2602-5054	-	M2.5x6	
A10Q-SDQCR/L3	.625	.406	7.0	.812	DCMT32.52	2602-5055	2602-5056	-	M2.5x8	T8
A12R-SDQCR/L3	.75	.75	8.0	1.00	DCMT32.52	2602-5057	2602-5058	-	M2.5x8	T8
A16S-SDQCR/L3	1.00	.651	10.0	1.25	DCMT32.52	2602-5059	2602-5060	-	M2.5x8	T8





# Cutoutil

Metal Carbide Inserts, Turning Tools, Indexable Milling, Carbide Drill

www.cutoutil.com

## S-SDUCR/L 93°内孔镗刀

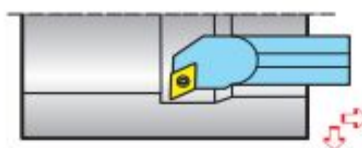

### S-SDUCR/L

型号 #	刀体几何尺寸				刀片	货号		刀垫	刀片螺钉	扳手
	D	F	L	最小镗孔		左刀	右刀			
S10K-SDUCR/L07	10	7	125	13	DCMT0702.	2603-2008	2603-3008	-	M2.5x6	
S12M-SDUCR/L07	12	9	150	16	DCMT0702.	2603-2010	2603-3010	-	M2.5x8	T8
S16R-SDUCR/L07	16	11	200	20	DCMT0702.	2603-2012	2603-3012	-	M2.5x8	
S20S-SDUCR/L11	20	13	250	25	DCMT11T3.	2603-2014	2603-3014	-	M4x10	
S25T-SDUCR/L11	25	17	300	32	DCMT11T3.	2603-2016	2603-3016	-	M4x10	T15
S32U-SDUCR/L11	32	22	350	40	DCMT11T3.	2603-2018	2603-3018	-	M4x10	
S40U-SDUCR/L11	40	27	350	50	DCMT11T3.	2603-2020	2603-3020	-	M4x10	

英制

MODEL #	DIMENSIONS				INSERT SIZE	ITEM NO.		SHIM	SCREW	WRENCH KEY
	D	F	L	MIN BORE		RIGHT	LEFT			
S06M-SDUCR/L2	.375	.250	6.00	.500	DCMT21.51	2603-8008	2603-9008	-	M2.5x6	
S08R-SDUCR/L2	.500	.312	8.00	.625	DCMT21.51	2603-8010	2603-9010	-	M2.5x8	T8
S10S-SDUCR/L2	.625	.406	10.0	.812	DCMT21.51	2603-8012	2603-9012	-	M2.5x8	
S12S-SDUCR/L3	.750	.500	10.0	1.00	DCMT32.52	2603-8014	2603-9014	-	M4x10	
S16T-SDUCR/L3	1.00	.651	12.0	1.25	DCMT32.52	2603-8016	2603-9016	-	M4x10	T15
S20U-SDUCR/L3	1.25	.875	14.0	1.50	DCMT32.52	2603-8018	2603-9018	-	M4x10	

### A-SDUCR/L (内冷却孔)

型号 #	刀体几何尺寸				刀片	货号		刀垫	刀片螺钉	扳手
	D	F	L	最小镗孔		左刀	右刀			
A12K-SDUCR/L07	12	9	125	16	DCMT0702.	2603-5001	2603-5002	-	M2.5x8	T8
A16M-SDUCR/L07	16	11	150	20	DCMT0702.	2603-5003	2603-5004	-	M2.5x8	
A20Q-SDUCR/L11	20	13	180	25	DCMT11T3.	2603-5005	2603-5006	-	M4x10	
A25R-SDUCR/L11	25	17	200	32	DCMT11T3.	2603-5007	2603-5008	-	M4x10	T15
A32S-SDUCR/L11	32	22	250	40	DCMT11T3.	2603-5009	2603-5010	-	M4x10	
A40T-SDUCR/L11	40	27	300	50	DCMT11T3.	2603-5011	2603-5012	-	M4x10	

英制

MODEL #	DIMENSIONS				INSERT SIZE	ITEM NO.		SHIM	SCREW	WRENCH KEY
	D	F	L	MIN BORE		RIGHT	LEFT			
A06J-SDUCR/L2	.375	.250	4.5	.500	DCMT21.51	2603-5013	2603-5012	-	M2.5x6	
A08M-SDUCR/L2	.500	.312	6.0	.625	DCMT21.51	2603-5015	2603-5014	-	M2.5x8	T8
A10Q-SDUCR/L2	.625	.406	7.0	.812	DCMT21.51	2603-5017	2603-5016	-	M2.5x8	
A12R-SDUCR/L3	.750	.500	8.0	1.00	DCMT32.52	2603-5019	2603-5020	-	M4x10	
A16S-SDUCR/L3	1.00	.651	10.0	1.25	DCMT32.52	2603-5021	2603-5022	-	M4x10	T15





# Cutoutil

Metal Carbide Inserts, Turning Tools, Indexable Milling, Carbide Drill

www.cutoutil.com

## S-SSKCR/L 75°内孔镗刀



### S-SSKCR/L

型号 #	刀体几何尺寸				刀片	货号		刀垫	刀片螺钉	扳手
	D	F	L	最小镗孔		左刀	右刀			
S16R-SSKCR/L09	16	11	200	20	SCMT09T3.	2604-2008	2604-3008	-	M4x8	T15
S20S-SSKCR/L09	20	13	250	25	SCMT09T3.	2604-2010	2604-3010	-	M4x10	T15
S25T-SSKCR/L12	25	17	300	32	SCMT1204.	2604-2012	2604-3012	-	M5x12	T20
S32U-SSKCR/L12	32	22	350	40	SCMT1204.	2604-2014	2604-3014	-	M5x12	T20
S40U-SSKCR/L12	40	27	350	50	SCMT1204.	2504-2016	2504-3016	-	M5x12	T20

英制

MODEL #	DIMENSIONS				INSERT SIZE	ITEM NO.		SHIM	SCREW	WRENCH KEY
	D	F	L	MIN BORE		RIGHT	LEFT			
S10R-SSKCR/L3	.625	.406	8.0	.75	SCMT32.52	2604-8008	2604-9008	-	M4x8	T15
S12S-SSKCR/L3	.750	.50	10.0	1.00	SCMT32.52	2604-8010	2604-9010	-	M4x10	T15
S16T-SSKCR/L4	1.00	.651	12.0	1.25	SCMT43.	2604-8012	2604-9012	-	M5x12	T20
S20U-SSKCR/L4	1.25	.875	14.0	1.50	SCMT43.	2604-8014	2604-9014	-	M5x12	T20
S24U-SSKCR/L4	1.50	1.062	14.0	2.00	SCMT43.	2604-8016	2604-9016	-	M5x12	T20

### A-SSKCR/L(内冷却孔)

型号 #	刀体几何尺寸				刀片	货号		刀垫	刀片螺钉	扳手
	D	F	L	最小镗孔		左刀	右刀			
A16M-SSKCR/L09	16	11	150	20	SCMT09T3.	2604-0001	2604-0002	-	M4x8	T15
A20Q-SSKCR/L09	20	13	180	25	SCMT09T3.	2604-0003	2604-0004	-	M4x10	T15
A25R-SSKCR/L12	25	17	200	32	SCMT1204.	2604-0005	2604-0006	-	M5x12	T20
A32S-SSKCR/L12	32	22	250	40	SCMT1204.	2604-0007	2604-0008	-	M5x12	T20
A40T-SSKCR/L12	40	27	300	50	SCMT1204.	2604-0009	2604-0010	-	M5x12	T20

英制

MODEL #	DIMENSIONS				INSERT SIZE	ITEM NO.		SHIM	SCREW	WRENCH KEY
	D	F	L	MIN BORE		RIGHT	LEFT			
A10Q-SSKCR/L3	.625	.406	7.0	.75	SCMT32.52	2604-0011	2604-0012	-	M4x8	T15
A12R-SSKCR/L3	.750	.50	8.0	1.00	SCMT32.52	2604-0013	2604-0014	-	M4x10	T15
A16S-SSKCR/L4	1.00	.651	10.0	1.25	SCMT43.	2604-0015	2604-0016	-	M5x12	T20
A20T-SSKCR/L4	1.25	.875	12.0	1.50	SCMT43.	2604-0017	2604-0018	-	M5x12	T20
A24T-SSKCR/L4	1.50	1.062	12.0	2.00	SCMT43.	2604-0019	2604-0020	-	M5x12	T20



# Cutoutil

Metal Carbide Inserts, Turning Tools, Indexable Milling, Carbide Drill

www.cutoutil.com

## S-STFCR/L 90°内孔镗刀



### S-STFCR/L

型号 #	刀体几何尺寸				刀片	货号		刀垫	刀片螺钉	扳手
	D	F	L	最小镗孔		左刀	右刀			
S08H-STFCR/L09	8	6	100	11	TCMT0902.	2605-2006	2605-3006	-	M2.2x6	T7
S10K-STFCR/L11	10	7	125	13	TCMT1102.	2605-2008	2605-3008	-	M2.5x6	
S12M-STFCR/L11	12	9	150	16	TCMT1102.	2605-2010	2605-3010	-	M2.5x8	T8
S16R-STFCR/L11	16	11	200	20	TCMT1102.	2605-2012	2605-3012	-		
S20S-STFCR/L16	20	13	250	25	TCMT16T3.	2605-2014	2605-3014	-		
S25T-STFCR/L16	25	17	300	32	TCMT16T3.	2605-2016	2605-3016	-		
S32U-STFCR/L16	32	22	350	40	TCMT16T3.	2605-2018	2605-3018	-	M4x10	T15
S40U-STFCR/L16	40	27	350	50	TCMT16T3.	2605-2020	2605-3020	-		

英制

MODEL #	DIMENSIONS				INSERT SIZE	ITEM NO.		SHIM	SCREW	WRENCH KEY
	D	F	L	MIN BORE		RIGHT	LEFT			
S06M-STFCR/L2	.375	.250	6.0	.500	TCMT21.51	2605-8008	2605-9008	-	M2.5x6	
S08Q-STFCR/L2	.500	.312	7.0	.625	TCMT21.51	2605-8010	2605-9010	-	M2.5x8	T8
S10R-STFCR/L2	.625	.406	8.0	.812	TCMT21.51	2605-8012	2605-9012	-		
S12S-STFCR/L3	.750	.500	10.0	1.00	TCMT32.52	2605-8014	2605-9014	-		
S16T-STFCR/L3	1.00	.651	12.0	1.25	TCMT32.52	2605-8016	2605-9016	-		
S20U-STFCR/L3	1.25	.875	14.0	1.50	TCMT32.52	2605-8018	2605-9018	-	M4x10	T15
S24U-STFCR/L3	1.50	1.062	14.0	2.00	TCMT32.52	2605-8020	2605-9020	-		

### A-STFCR/L(带内冷却孔)

型号 #	刀体几何尺寸				刀片	货号		刀垫	刀片螺钉	扳手
	D	F	L	最小镗孔		左刀	右刀			
A12K-STFCR/L11	12	9	125	16	TCMT1102.	2605-5001	2605-5002	-	M2.5x8	T8
A16M-STFCR/L11	16	11	150	20	TCMT1102.	2605-5003	2605-5004	-		
A20Q-STFCR/L16	20	13	180	25	TCMT16T3.	2605-5005	2605-5006	-		
A25R-STFCR/L16	25	17	200	32	TCMT16T3.	2605-5007	2605-5008	-	M4x10	T15
A32S-STFCR/L16	32	22	250	40	TCMT16T3.	2605-5009	2605-5010	-		
A40T-STFCR/L16	40	27	300	50	TCMT16T3.	2605-5011	2605-5012	-		

英制

MODEL #	DIMENSIONS				INSERT SIZE	ITEM NO.		SHIM	SCREW	WRENCH KEY
	D	F	L	MIN BORE		RIGHT	LEFT			
A06J-STFCR/L2	.375	.250	4.50	.500	TCMT21.51	2605-5013	2605-5012	-	M2.5x6	
A08M-STFCR/L2	.500	.312	6.00	.625	TCMT21.51	2605-5015	2605-5014	-	M2.5x8	T8
A10Q-STFCR/L2	.625	.406	7.00	.812	TCMT21.51	2605-5017	2605-5016	-		
A12R-STFCR/L3	.750	.500	8.00	1.00	TCMT32.52	2605-5019	2605-5018	-		
A16S-STFCR/L3	1.00	.651	10.0	1.25	TCMT32.52	2605-5021	2605-5020	-		
A20T-STFCR/L3	1.25	.875	12.0	1.50	TCMT32.52	2605-5023	2605-5022	-	M4x10	T15
A24T-STFCR/L3	1.50	1.062	12.0	2.00	TCMT32.52	2605-5025	2605-5024	-		





# Cutoutil

Metal Carbide Inserts, Turning Tools, Indexable Milling, Carbide Drill

www.cutoutil.com

## S-SVQBR/L 107.5°内孔镗刀

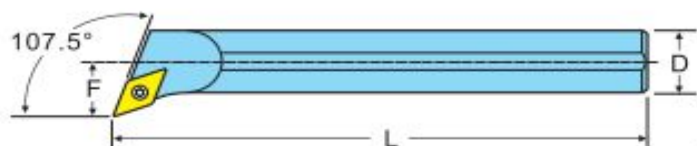
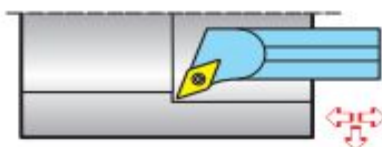

### S-SVQBR/L

型号 #	刀体几何尺寸				刀片	货号		刀垫	刀片螺钉	扳手
	D	F	L	最小镗孔		左刀	右刀			
S16R-SVQBR/L11	16	11	200	20	VBMT1102.	2606-0008	2606-1008			
S20S-SVQBR/L11	20	13	250	25	VBMT1102.	2606-0010	2606-1010	-	M2.5x8	T8
S25T-SVQBR/L11	25	17	300	32	VBMT1102.	2606-0012	2606-1012			
S25T-SVQBR/L16	25	17	300	32	VBMT1604.	2606-0014	2606-1014			
S32U-SVQBR/L16	32	22	350	40	VBMT1604.	2606-0016	2606-1016	-	M4x10	T15
S40U-SVQBR/L16	40	27	350	50	VBMT1604.	2606-0018	2606-1018			

英制

MODEL #	DIMENSIONS				INSERT SIZE	ITEM NO.		SHIM	SCREW	WRENCH KEY
	D	F	L	MIN BORE		RIGHT	LEFT			
S10R-SVQBR/L2	.625	.406	8.0	.812	VBMT21.5.	2606-6014	2606-7014			
S12S-SVQBR/L2	.75	.500	10.0	1.00	VBMT21.5.	2606-6016	2606-7016	-	M2.5x8	T8
S16T-SVQBR/L2	1.00	.651	12.0	1.25	VBMT21.5.	2606-6018	2606-7018			
S16T-SVQBR/L3	1.00	.651	12.0	1.25	VBMT332.	2606-6020	2606-7020			
S20U-SVQBR/L3	1.25	.875	14.0	1.50	VBMT332.	2606-6022	2606-7022	-	M4x10	T15
S24U-SVQBR/L3	1.50	1.062	14.0	2.00	VBMT332.	2606-6024	2606-7024			

### A-SVQBR/L(带内冷却孔)

型号 #	刀体几何尺寸				刀片	货号		刀垫	刀片螺钉	扳手
	D	F	L	最小镗孔		左刀	右刀			
A16M-SVQBR/L11	16	11	150	20	VBMT1102.	2606-5001	2606-5002			
A20Q-SVQBR/L11	20	13	180	25	VBMT1102.	2606-5003	2606-5004	-	M2.5x8	T8
A25R-SVQBR/L11	25	17	200	32	VBMT1102.	2606-5005	2606-5006			
A25R-SVQBR/L16	25	17	200	32	VBMT1604.	2606-5007	2606-5008			
A32S-SVQBR/L16	32	22	250	40	VBMT1604.	2606-5009	2606-5010	-	M4x10	T15
A40T-SVQBR/L16	40	27	300	50	VBMT1604.	2606-5011	2606-5012			

英制

MODEL #	DIMENSIONS				INSERT SIZE	ITEM NO.		SHIM	SCREW	WRENCH KEY
	D	F	L	MIN BORE		RIGHT	LEFT			
A10Q-SVQBR/L2	.625	.406	7.0	.812	VBMT21.5.	2606-5013	2606-5014			
A12R-SVQBR/L2	.75	.500	8.0	1.00	VBMT21.5.	2606-5015	2606-5016	-	M2.5x8	T8
A16S-SVQBR/L2	1.00	.651	10.0	1.25	VBMT21.5.	2606-5017	2606-5018			
A16S-SVQBR/L3	1.00	.651	10.0	1.25	VBMT332.	2606-5019	2606-5020			
A20T-SVQBR/L3	1.25	.875	12.0	1.50	VBMT332.	2606-5021	2606-5022	-	M4x10	T15
A24T-SVQBR/L3	1.50	1.062	12.0	2.00	VBMT332.	2606-5023	2606-5024			







# Cutoutil

Metal Carbide Inserts, Turning Tools, Indexable Milling, Carbide Drill

www.cutoutil.com

## S-PCLNR/L 95° 杠杆式内孔镗刀



CNMG, CNMA, CNMM

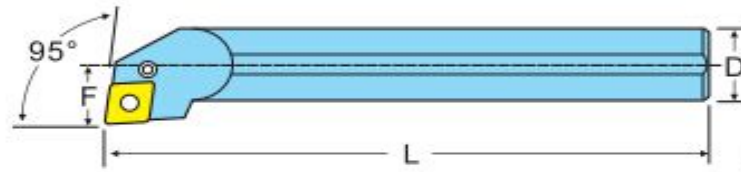
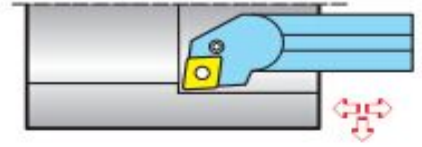

## S-PCLNR/L

型号 #	刀体几何尺寸				刀片	货号		刀垫	弹簧套	杠杆	杠杆螺丝	扳手
	D	F	L	最小镗孔		左刀	右刀					
S16R-PCLNR/L09	16	11	200	20	CNMG0903	2640-0008	2640-1008			NG0310A	LGL0613	S3
S20S-PCLNR/L12	20	13	250	25	CNMG1204	2640-0010	2640-1010			NG0514-W	NGL0817	S4
S25T-PCLNR/L12	25	17	300	32	CNMG1304	2640-0012	2640-1012			GL0820		
S32U-PCLNR/L12	25	22	350	40	CNMG1204	2640-0014	2640-1014			G0514-W	NGL0817	S4
S40U-PCLNR/L12	32	27	350	50	CNMG1204	2640-0016	2640-1016	C12A	GH0607	GL0820		
S50V-PCLNR/L12	40	35	400	64	CNMG1204	2640-0018	2640-1018			NG0616-W	GL0820	S4
S32U-PCLNR/L16	32	22	350	40	CNMG1606	2640-0020	2640-1020			G0616-W	GL0826	
S40U-PCLNR/L16	40	27	350	50	CNMG1606	2640-0022	2640-1022	C16A	GH0709			S4
S50V-PCLNR/L16	50	35	400	63	CNMG1606	2640-0024	2640-1024					

英制

MODEL #	DIMENSIONS				INSERT SIZE	ITEM NO.		SHIM	SHIM PIN	CLAMP	CLAMP SCREW	WRENCH
	D	F	L	MIN BORE		RIGHT	LEFT					
S10R-PCLNR/L3	.625	.406	8.0	.812	CNMG322	2640-2008	2640-3008			NG0310A	LGL0613	S3
S12S-PCLNR/L4	.75	.50	10.0	1.00	CNMG432	2640-2010	2640-3010			NG0514-W	NGL0817	S4
S16T-PCLNR/L4	1.00	.651	12.0	1.25	CNMG432	2640-2012	2640-3012			GL0820		
S20U-PCLNR/L4	1.25	.875	14.0	1.50	CNMG432	2640-2014	2640-3014	C12A	GH0607	G0514-W	GL0820	S4
S24U-PCLNR/L4	1.50	1.062	14.0	2.00	CNMG432	2640-2016	2640-3016			GL0822		
S20U-PCLNR/L5	1.25	.875	14.0	1.50	CNMG543	2640-2018	2640-3018	C16A	GH0709	NG0616-W	GL0820	S4
S24U-PCLNR/L5	1.50	1.062	14.0	2.00	CNMG543	2640-2020	2640-3020			G0616-W	GL0826	

## A-PCLNR/L (内冷却孔)

型号 #	刀体几何尺寸				刀片	货号		刀垫	刀垫螺钉	杠杆	杠杆螺钉	扳手
	D	F	L	最小镗孔		左刀	右刀					
A16M-PCLNR/L09	16	11	150	20	CNMG0903	2640-5001	2640-5002			NG0310A	LGL0613	S3
A20Q-PCLNR/L12	20	13	180	25	CNMG1204	2640-5003	2640-5004			NG0514-W	NGL0817	S4
A25R-PCLNR/L12	25	17	200	32	CNMG1304	2640-5005	2640-5006			GL0820		
A32S-PCLNR/L12	25	22	250	40	CNMG1204	2640-5007	2640-5008			G0514-W	NGL0817	S4
A40T-PCLNR/L12	32	27	300	50	CNMG1204	2640-5009	2640-5010	C12A	GH0607	GL0820		
A32S-PCLNR/L16	40	22	250	40	CNMG1204	2640-5011	2640-5012			GL0820		S4
A40T-PCLNR/L16	32	27	300	50	CNMG1606	2640-5013	2640-5014	C16A	GH0709	G0616-W	GL0826	

英制

MODEL #	DIMENSIONS				INSERT SIZE	ITEM NO.		SHIM	SHIM PIN	CLAMP	CLAMP SCREW	WRENCH
	D	F	L	MIN BORE		RIGHT	LEFT					
A10Q-PCLNR/L3	.625	.406	7.0	.812	CNMG32	2640-5015	2640-5016			NG0310A	LGL0613	S3
A12R-PCLNR/L4	.75	.50	8.0	1.0	CNMG43	2640-5017	2640-5018			NG0514-W	NGL0817	S4
A16S-PCLNR/L4	1.00	.651	10.0	1.25	CNMG43	2640-5019	2640-5020			GL0820		
A20T-PCLNR/L4	1.25	.875	12.0	1.5	CNMG43	2640-5021	2640-5022	C12A	GH0607	G0514-W	GL0820	S4
A24T-PCLNR/L4	1.50	1.062	12.0	2.0	CNMG43	2640-5023	2640-5024			GL0822		





# Cutoutil

Metal Carbide Inserts, Turning Tools, Indexable Milling, Carbide Drill

www.cutoutil.com

## S-PWLNLR/L 95°内孔镗刀

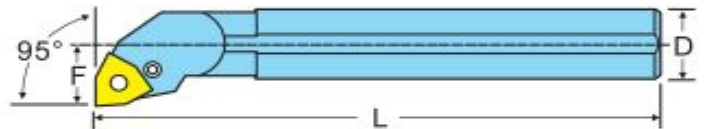
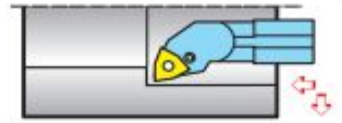

### S-PWLNLR/L

型号 #	刀体几何尺寸				刀片	货号		刀垫	弹簧套	缸杆	缸杆螺丝	扳手
	D	F	L	最小镗孔		左刀	右刀					
S20S-PWLNLR/L08	20	13	250	22	WNMM0804	2645-0010	2645-1010					
S25T-PWLNLR/L08	25	17	300	27	WNMM0804	2645-0012	2645-1012			NG0514-W	NGL0817	
S32U-PWLNLR/L08	32	22	350	33	WNMM0804	2645-0014	2645-1014					S4
S40U-PWLNLR/L08	40	27	350	33	WNMM0804	2645-0016	2645-1016	W08A	GH0607	NG0514-W	NGL0817	
S50V-PWLNLR/L08	50	35	400	40	WNMM0804	2645-0018	2645-1018					

英制

MODEL #	DIMENSIONS				INSERT SIZE	ITEM NO.		SHIM	SHIM PIN	CLAMP	CLAMP SCREW	WRENCH
	D	F	L	MIN BORE		RIGHT	LEFT					
S12S-PWLNLR/L4	.75	.50	10.0	1.00	WNMM432	2645-0010	2645-1010					
S16T-PWLNLR/L4	1.00	.651	12.0	1.25	WNMM432	2645-0012	2645-1012			NG0514-W	NGL0817	
S20U-PWLNLR/L4	1.25	.875	14.0	1.50	WNMM432	2645-0014	2645-1014					S4
S24U-PWLNLR/L4	1.50	1.062	14.0	2.00	WNMM432	2645-0016	2645-1016	W08A	GH0607	NG0514-W	NGL0820	

### A-PWLNLR/L

型号 #	刀体几何尺寸				刀片	货号		刀垫	刀垫螺钉	缸杆	缸杆螺钉	扳手
	D	F	L	最小镗孔		左刀	右刀					
A20Q-PWLNLR/L08	20	13	180	25	WNMM0804	2645-5001	2645-5002					
A25R-PWLNLR/L08	25	17	200	32	WNMM0804	2645-5003	2645-5004			NG0514-W	NGL0817	
A32S-PWLNLR/L08	32	22	250	40	WNMM0804	2645-5005	2645-5006					S4
A40T-PWLNLR/L08	40	27	300	50	WNMM0804	2645-5007	2645-5008	W08A	GH0607	NG0514-W	NGL0817	
A50T-PWLNLR/L08	50	35	300	63	WNMM0804	2645-5009	2645-5010					

英制

MODEL #	DIMENSIONS				INSERT SIZE	ITEM NO.		SHIM	SHIM PIN	CLAMP	CLAMP SCREW	WRENCH
	D	F	L	MIN BORE		RIGHT	LEFT					
A12R-PWLNLR/L4	.75	.50	8.0	1.00	WNMM432	2645-5011	2645-5012					
A16S-PWLNLR/L4	1.00	.651	10.0	1.25	WNMM432	2645-5013	2645-5014			NG0514-W	NGL0817	
A20T-PWLNLR/L4	1.25	.875	12.0	1.50	WNMM432	2645-5015	2645-5016					S4
A24T-PWLNLR/L4	1.50	1.062	12.0	2.00	WNMM432	2645-5017	2645-5018	W08A	GH0607	NG0514-W	NGL0820	





# Cutoutil

Metal Carbide Inserts, Turning Tools, Indexable Milling, Carbide Drill

www.cutoutil.com

## S-PTFNR/L 90°杠杆式内孔镗刀

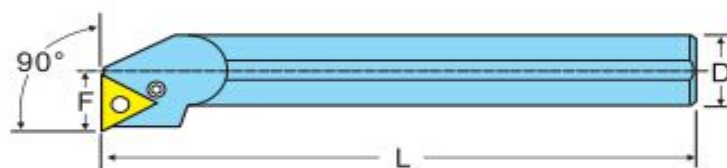

TNMG TNMA

### S-PTFNR/L

型号 #	刀体几何尺寸				刀片	货号		刀垫	弹簧套	缸杯	缸杯螺丝	扳手
	D	F	L	最小镗孔		左刀	右刀					
S20S-PTFNR/L16	20	13	250	25	TNMM1604	2644-0010	2644-1010			NG0310A	LGL0613	S3
S25T-PTFNR/L16	25	17	300	32	TNMM1604	2644-0012	2644-1012				NGL0617	
S32U-PTFNR/L16	32	22	350	40	TNMM1604	2644-0014	2644-1014				GL0620	
S40U-PTFNR/L16	40	27	350	50	TNMM1604	2644-0016	2644-1016	T16A	GH0405	G0310-W		
S50V-PTFNR/L16	50	35	400	63	TNMM1604	2644-0018	2644-1018					

英制

MODEL #	DIMENSIONS				INSERT SIZE	ITEM NO.		SHIM	SHIM PIN	CLAMP	CLAMP SCREW	WRENCH
	D	F	L	MIN BORE		RIGHT	LEFT					
S12S-PTFNR/L3	.75	.509	10.0	1.00	TNMM322	2644-2008	2644-3008			NG0310A	LGL0613	S3
S16T-PTFNR/L3	1.00	.651	12.0	1.25	TNMM332	2644-2010	2644-3010				NGL0617	
S20U-PTFNR/L3	1.25	.875	14.0	1.50	TNMM332	2644-2012	2644-3012				GL0620	
S24U-PTFNR/L3	1.50	1.062	14.0	2.00	TNMM332	2644-2014	2644-3014	T16A	GH0405	G0310-W		

### A-PTFNR/L (内冷却孔)

型号 #	刀体几何尺寸				刀片	货号		刀垫	弹簧套	缸杯	缸杯螺钉	扳手
	D	F	L	最小镗孔		左刀	右刀					
A20Q-PTFNR/L16	20	13	180	25	TNMM1604	2644-5001	2644-5002			NG0310A	LGL0613	S3
A25R-PTFNR/L16	25	17	200	32	TNMM1604	2644-5003	2644-5004				NGL0617	
A32S-PTFNR/L16	32	22	250	40	TNMM1604	2644-5005	2644-5006				GL0620	
A40T-PTFNR/L16	40	27	300	50	TNMM1604	2644-5007	2644-5008	T16A	GH0405	G0310-W		
A50T-PTFNR/L16	50	35	300	63	TNMM1604	2644-5009	2644-5010					

英制

MODEL #	DIMENSIONS				INSERT SIZE	ITEM NO.		SHIM	SHIM PIN	CLAMP	CLAMP SCREW	WRENCH
	D	F	L	MIN BORE		RIGHT	LEFT					
A12R-PCLNR/L3	.75	.509	8.0	1.00	TNMM33	2640-5015	2640-5016			NG0310A	LGL0613	S3
A16S-PCLNR/L4	1.00	.651	10.0	1.25	TNMM33	2640-5017	2640-5018				NGL0617	
A20T-PCLNR/L4	1.25	.875	12.0	1.50	TNMM33	2640-5019	2640-5020				GL0620	
A24T-PCLNR/L4	1.50	1.062	12.0	2.00	TNMM33	2640-5021	2640-5022	T16A	GH0405	G0310-W		



# Cutoutil

Metal Carbide Inserts, Turning Tools, Indexable Milling, Carbide Drill

www.cutoutil.com

## S-PDUNR/L 93°内孔镗刀



DNMG, DNMA

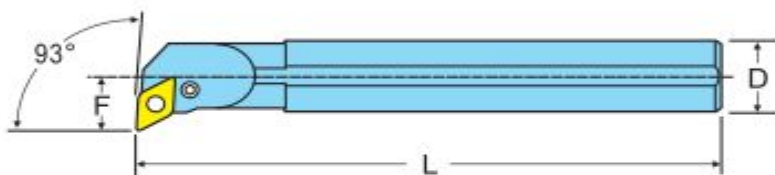
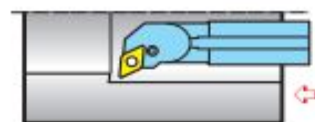

### S-PDUNR/L

型号 #	刀体几何尺寸				刀片	货号		刀垫	弹簧套	缸杆	缸杆螺钉	扳手
	D	F	L	最小镗孔		左刀	右刀					
S25T-PDUNR/L15	25	17	300	32	DNMG1506	2642-0010	2642-1010			NG0517-W	GL0820	S4
S32U-PDUNR/L15	32	22	350	40	DNMG1506	2642-0012	2642-1012					
S40U-PDUNR/L15	40	27	350	50	DNMG1506	2642-0014	2642-1014	D15A	GH0607	G0517-W	GL0826	
S50V-PDUNR/L15	50	35	400	63	DNMG1506	2642-0016	2642-1016					

英制

MODEL #	DIMENSIONS				INSERT SIZE	ITEM NO.		SHIM	SHIM PIN	CLAMP	CLAMP SCREW	WRENCH
	D	F	L	MIN BORE		RIGHT	LEFT					
S16T-PDUNR/L15	1.00	.851	12.0	1.25	DNMG442	2642-2010	2642-3010			NG0517-W	GL0820	S4
S20U-PDUNR/L15	1.25	.875	14.0	1.50	DNMG442	2642-2012	2642-3012				GL0822	
S24U-PDUNR/L15	1.50	1.062	14.0	2.00	DNMG442	2642-2014	2642-3014	D15A	GH0607	G0517-W	GL0826	

### A-PDUNR/L

型号 #	刀体几何尺寸				刀片	货号		刀垫	弹簧套	缸杆	缸杆螺钉	扳手
	D	F	L	最小镗孔		左刀	右刀					
A25R-PDUNR/L15	25	17	200	32	DNMM1506	2642-5001	2642-5002			NG0517-W	GL0820	S4
A32S-PDUNR/L15	32	22	250	40	DNMM1506	2642-5003	2642-5004				GL0822	
A40T-PDUNR/L15	40	27	300	50	DNMM1506	2642-5005	2642-5006	D15A	GH0607	G0517-W	GL0826	
A50T-PDUNR/L15	50	35	300	63	DNMM1506	2642-5007	2642-5008					

英制

MODEL #	DIMENSIONS				INSERT SIZE	ITEM NO.		SHIM	SHIM PIN	CLAMP	CLAMP SCREW	WRENCH
	D	F	L	MIN BORE		RIGHT	LEFT					
A16S-PDUNR/L4	1.00	.851	10.0	1.25	DNMM442	2642-5013	2642-5014				GL0820	S4
A20T-PDUNR/L4	1.25	.875	12.0	1.50	DNMM442	2642-5015	2642-5016			G0517-W	GL0822	
A24T-PDUNR/L4	1.50	1.062	12.0	2.00	DNMM442	2642-5017	2642-5018	D15A	GH0607		GL0826	





# Cutoutil

Metal Carbide Inserts, Turning Tools, Indexable Milling, Carbide Drill

www.cutoutil.com

## S-PSKNR/L 75°杠杆式内孔镗刀

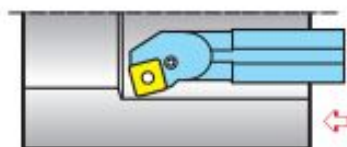

### S-PSKNR/L

型号 #	刀体几何尺寸				刀片	货号		刀垫	刀垫螺钉	缸杆	缸杆螺钉	扳手
	D	F	L	最小镗孔		左刀	右刀					
S25T-PSKNR/L12	25	17	300	32	SNMG1204	2643-0010	2643-1010			NG0514-W	NGL0817	
S32U-PSKNR/L12	32	22	350	40	SNMG1204	2643-0012	2643-1012				GL0820	
S40U-PSKNR/L12	40	27	350	50	SNMG1204	2643-0014	2643-1014	S12A	GH0607	G0514-W	GL0822	S4
S50V-PSKNR/L12	50	35	400	63	SNMG1204	2643-0016	2643-1016					
S32U-PSKNR/L15	32	22	350	40	SNMG1506	2643-0018	2643-1018				GL0820	
S40U-PSKNR/L15	40	27	350	50	SNMG1506	2643-0020	2643-1020	S15A	GH0709	G0616-W	GL0826	
S50V-PSKNR/L15	50	35	400	63	SNMG1506	2643-0022	2643-1022					

英制

MODEL #	DIMENSIONS				INSERT SIZE	ITEM NO.		SHIM	SHIM PIN	CLAMP	CLAMP SCREW	WRENCH
	D	F	L	MIN BORE		RIGHT	LEFT					
S16T-PSKNR/L4	1.00	.651	12.0	1.25	SNMG432	2643-2008	2643-3008			NG0514-W	NGL0817	
S20U-PSKNR/L4	1.25	.875	14.0	1.50	SNMG432	2643-2010	2643-3010				GL0820	
S24U-PSKNR/L4	1.50	1.062	14.0	2.00	SNMG432	2643-2012	2643-3012	S12A	GH0607	G0514-W	GL0822	S4
S20U-PSKNR/L5	1.25	.875	14.0	1.50	SNMG542	2643-2014	2643-3014				GL0820	
S24U-PSKNR/L5	1.50	1.062	14.0	2.00	SNMG542	2643-2016	2643-3016	S15A	GH0709	G0616-W	GL0826	





# Cutoutil

Metal Carbide Inserts, Turning Tools, Indexable Milling, Carbide Drill

www.cutoutil.com

## S-DCLNR/L 95°内孔镗刀

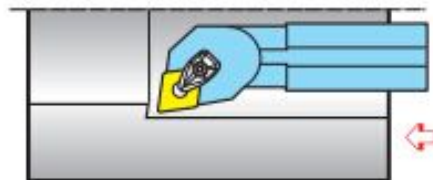

### S-DCLNR/L

型号 #	刀体几何尺寸				刀片	货号		刀垫	刀垫螺钉	压板	压板螺钉	扳手/卡圈
	D	F	L	最小镗孔		左刀	右刀					
S20S-DCLNR/L09	20	13	250	25	CNMG0903	2620-0010	2620-1010	C0903B	LTM5x8	DLM-3	LE-05	S3/E3.5
S25T-DCLNR/L12	25	17	300	32	CNMG1204	2620-0012	2620-1012	C1203B	LYM6x10	DLM-4	LE-06	S4/E4
S32U-DCLNR/L12	32	22	350	40	CNMG1204	2620-0014	2620-1014					
S40U-DCLNR/L12	40	27	350	50	CNMG1204	2620-0016	2620-1016	C1604B	LYM8x10			
S32U-DCLNR/L16	32	22	350	40	CNMG1606	2620-0018	2620-1018					
S40U-DCLNR/L16	40	27	350	50	CNMG1606	2620-0020	2620-1020					

### 英制

MODEL #	DIMENSIONS				INSERT SIZE	ITEM NO.		SHIM	SHIM PIN	CLAMP	CLAMP SCREW	WRENCH
	D	F	L	MIN BORE		RIGHT	LEFT					
S12S-DCLNR/L3	.75	.50	10.0	1.00	CNMG32	2620-3010	2620-4010	C0903B	LTM5x8	DLM-3	LE-05	S3/E3.5
S16T-DCLNR/L4	1.00	.651	12.0	1.25	CNMG43	2620-3012	2620-4012	C1203B	LYM6x10	DLM-4	LE-06	S4/E4
S20U-DCLNR/L4	1.25	.875	14.0	1.50	CNMG43	2620-3014	2620-4014					
S24U-DCLNR/L4	1.50	1.062	14.0	2.00	CNMG43	2620-3016	2620-4016	C1604B	LYM8x10			
S20U-DCLNR/L5	1.25	.875	14.0	1.50	CNMG54	2620-3018	2620-4018					
S24U-DCLNR/L5	1.50	1.062	14.0	2.00	CNMG54	2620-3020	2620-4020					



# Cutoutil

Metal Carbide Inserts, Turning Tools, Indexable Milling, Carbide Drill

www.cutoutil.com

## S-DTFNR/L 90°拉压式内孔镗刀

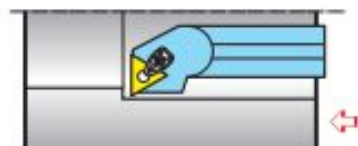

### S-DTFNR/L

型号 #	刀体几何尺寸				刀片	货号		刀垫	刀垫螺钉	压板	压板螺钉	扳手/卡圈
	D	F	L	最小镗孔		左刀	右刀					
S20S-DTFNR/L16	20	13	250	25	TNMG1604	2619-0010	2619-1010	T1603B	LTM5x8	DLM-3	LE-05	S3/E3.5
S25T-DTFNR/L16	25	17	300	32	TNMG1604	2619-0012	2619-1012					
S32U-DTFNR/L16	32	22	350	40	TNMG1604	2619-0014	2619-1014					
S40U-DTFNR/L16	40	27	350	50	TNMG1604	2619-0016	2619-1016					

英制

MODEL #	DIMENSIONS				INSERT SIZE	ITEM NO.		SHIM	SHIM PIN	CLAMP	CLAMP SCREW	WRENCH
	D	F	L	MIN BORE		RIGHT	LEFT					
S12S-DTFNR/L3	.75	.50	10.0	1.00	TNMG332	2619-2008	2619-3008	T1603B	LTM5x8	DLM-3	LE-05	S3/E3.5
S16T-DTFNR/L3	1.00	.651	12.0	1.25	TNMG332	2619-2010	2619-3010					
S20U-DTFNR/L3	1.25	.875	14.0	1.50	TNMG332	2619-2012	2619-3012					
S24U-DTFNR/L3	1.50	1.062	14.0	2.00	TNMG332	2619-2014	2619-3014					





# Cutoutil

Metal Carbide Inserts, Turning Tools, Indexable Milling, Carbide Drill

www.cutoutil.com

## S-CTFNR/L 90°上压式内孔镗刀



## S-CTFPR/L

型号 #	刀体几何尺寸				刀片	货号		刀架	刀垫螺钉	压板	压板螺钉	扳手
	D	F	L	最小镗孔		左刀	右刀					
S12M-CTFPR/L11	12	9	150	16	TPGN1103.	2610-0010	2610-1010	TP16D	M3x8	CTFPN-4	CTFP-M4	S2.5/E3
S16Q-CTFPR/L11	16	11	180	20	TPGN1103.	2610-0012	2610-1012			CTFPN-5	CTFP-M5	S3/E3
S20R-CTFPR/L16	20	13	200	25	TPGN1603.	2610-0014	2610-1014					
S25S-CTFPR/L16	25	17	250	32	TPGN1603.	2610-0016	2610-1016					
S32T-CTFPR/L16	32	22	300	40	TPGN1603.	2610-0018	2610-1018					
S40U-CTFPR/L16	40	27	350	50	TPGN1603.	2610-0020	2610-1020					

英制

MODEL #	DIMENSIONS				INSERT SIZE	ITEM NO.		SHIM	SHIM PIN	CLAMP	CLAMP SCREW	WRENCH
	D	F	L	MIN BORE		RIGHT	LEFT					
S08M-CTFPR/L2	.50	.312	6.0	.625	TPGN221	2610-2006	2610-3006	TP16D	M3x8	CTFPN-4	CTFP-M4	S2.5/E3
S10Q-CTFPR/L2	.625	.406	7.0	.812	TPGN221	2610-2008	2610-3008			CTFPN-5	CTFP-M5	S3/E3
S12R-CTFPR/L3	.75	.500	8.0	1.00	TPGN321	2610-2010	2610-3010					
S16S-CTFPR/L3	1.00	.651	10.0	1.25	TPGN321	2610-2012	2610-3012					
S20T-CTFPR/L3	1.25	.875	12.0	1.50	TPGN321	2610-2014	2610-3014					
S24U-CTFPR/L3	1.50	1.062	14.0	2.00	TPGN321	2610-2016	2610-3016					
S24U-CTFPR/L4	1.50	1.062	14.0	2.00	TPGN432	2610-2018	2610-3018	TP22D	M3x8	CTFPN-6	CTFP-M6	S4/E3.5



# Cutoutil

Metal Carbide Inserts, Turning Tools, Indexable Milling, Carbide Drill

www.cutoutil.com

## S-WTUNR/L 93°楔压式内孔镗刀

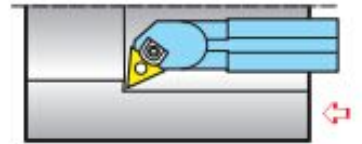

## S-WTUNR/L

型号 #	刀体几何尺寸				刀片	货号		刀架 WST163	刀架螺钉 WSP30514	压板 X1518	压板螺钉 M5x20	扳手/卡圈 S2.5/S4 E3.5
	D	F	L	最小镗孔		左刀	右刀					
S25T-WTUNR/L16	25	17	300	32	TNMG1604.	2621-0010	2621-1010					
S32U-WTUNR/L16	32	22	350	40	TNMG1604.	2621-0012	2621-1012					
S40V-WTUNR/L16	40	27	400	50	TNMG1604.	2621-0014	2621-1014					
S50W-WTUNR/L16	50	35	450	63	TNMG1604.	2621-0016	2621-1016					

## 英制

MODEL #	DIMENSIONS				INSERT SIZE	ITEM NO.		SHIM WST163	SHIM PIN WSP30514	CLAMP X1518	CLAMP SCREW M5x20	WRENCH S2.5/S4 E4
	D	F	L	MIN BORE		RIGHT	LEFT					
S16S-WTUNR/L3	1.00	.651	10.0	1.25	TNMG332	2621-2008	2621-3008					
S20T-WTUNR/L3	1.25	.875	12.0	1.50	TNMG332	2621-2010	2621-3010					
S24U-WTUNR/L3	1.50	1.062	14.0	2.00	TNMG332	2621-2012	2621-3012					



# Cutoutil

Metal Carbide Inserts, Turning Tools, Indexable Milling, Carbide Drill

www.cutoutil.com

## S-WWLNR/L 95°楔压式内孔镗刀

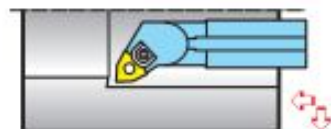

WNMM, WNMG

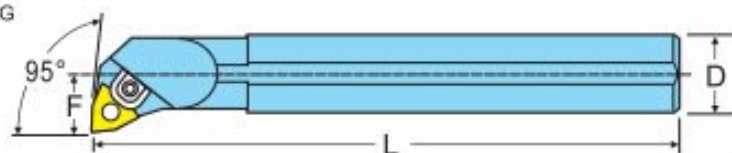

## S-WWLNR/L

型号 #	刀体几何尺寸				刀片	货号		刀垫	螺纹销	压板	压板螺钉	扳手/卡圈
	D	F	L	最小镗孔		左刀	右刀					
S25T-WWLNR/L08	25	17	300	32	WNMG0804.	2622-0020	2622-1020		WSP00611			
S32U-WWLNR/L08	32	22	350	40	WNMG0804.	2622-0022	2622-1022			WW08C	M5x20	S3/S4 E4
S40V-WWLNR/L08	40	27	400	50	WNMG0804.	2622-0024	2622-1024	WSW0804	WSP40617			
S50W-WWLNR/L08	50	35	450	63	WNMG0804.	2622-0026	2622-1026					

## 英制

MODEL #	DIMENSIONS				INSERT SIZE	ITEM NO.		SHIM	SHIM PIN	CLAMP	CLAMP SCREW	WRENCH
	D	F	L	MIN BORE		RIGHT	LEFT					
S16S-WWLNR/L4	1.00	.651	10.0	1.25	WNMG44.	2622-2012	2622-3012		WSP00611			
S20T-WWLNR/L4	1.25	.875	12.0	1.50	WNMG44.	2622-2014	2622-3014			WW08C	M5x20	S3/S4 E4
S24U-WWLNR/L4	1.50	1.062	14.0	2.00	WNMG44.	2622-2016	2622-3016	WSW0804	WSP40617			





# Cutoutil

Metal Carbide Inserts, Turning Tools, Indexable Milling, Carbide Drill

www.cutoutil.com

## S-MCLNR/L 95°内孔镗刀

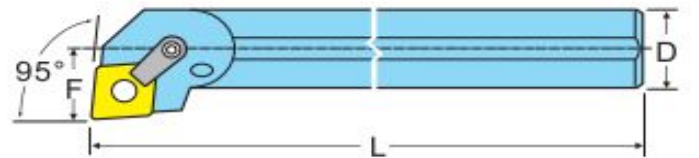
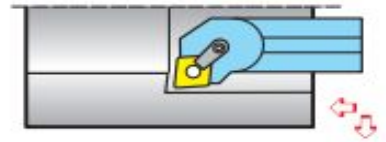

### S-MCLNR/L

型号 #	刀具几何尺寸				刀片	货号		刀架	锥度销	压板	压板螺钉	扳手
	D	F	L	最小镗孔		左刀	右刀					
S20S-MCLNR/L12	20	13	250	25	CNMM1204	2613-0010	2621-1010	/	NL-0611	CL-6	XNS-0520	S2.5
S25T-MCLNR/L12	25	17	300	32	CNMM1204	2613-0012	2621-1012					
S32U-MCLNR/L12	32	22	350	40	CNMM1204	2613-0014	2621-1014	C1203B	NL-0617	CL-6	XNS-0520	S2.5
S40U-MCLNR/L12	40	27	350	50	CNMM1204	2613-0016	2621-1016					
S50V-MCLNR/L12	50	35	400	63	CNMM1204	2613-0018	2621-1018	C1604B	NL-0822	CL-12	XNS-0829	S3/S4
S32U-MCLNR/L16	32	22	350	40	CNMM1606	2613-0020	2621-1020					
S40U-MCLNR/L16	40	27	350	50	CNMM1606	2613-0022	2621-1022	C1604B	NL-0822	CL-12	XNS-0829	S3/S4
S50V-MCLNR/L16	50	35	400	63	CNMM1606	2613-0024	2621-1024					

英制

MODEL #	DIMENSIONS				INSERT SIZE	ITEM NO.		SHIM	PIN	CLAMP	CLAMP SCREW	WRENCH
	D	F	L	MIN BORE		RIGHT	LEFT					
S12S-MCLNR/L4	.75	.50	10.0	1.00	CNMG432	2613-2008	2613-3008	/	NL-0611	CL-6	XNS-0520	S2.5
S16T-MCLNR/L4	1.00	.651	12.0	1.25	CNMG432	2613-2010	2613-3010					
S20U-MCLNR/L4	1.25	.875	14.0	1.50	CNMG432	2613-2012	2613-3012	C1203B	NL-0617	CL-6	XNS-0520	S2.5
S24U-MCLNR/L4	1.50	1.062	14.0	2.00	CNMG432	2613-2014	2613-3014					
S20T-MCLNR/L5	1.25	.875	14.0	1.50	CNMG543	2613-2016	2613-3016	C1604B	NL-0822	CL-12	XNS-0829	S3/S4
S24U-MCLNR/L5	1.50	1.062	14.0	2.00	CNMG543	2613-2018	2613-3018					

### A-MCLNR/L(内冷却孔)

型号 #	刀具几何尺寸				刀片	货号		刀架	锥度销	压板	压板螺钉	扳手
	D	F	L	最小镗孔		左刀	右刀					
A20Q-MCLNR/L12	20	13	180	25	CNMM1204	2613-5010	2613-6010	/	NL-0611	CL-6	XNS-0520	S2.5
A25R-MCLNR/L12	25	17	200	32	CNMM1204	2613-5012	2613-6012					
A32S-MCLNR/L12	32	22	250	40	CNMM1204	2613-5014	2613-6014	C1203B	NL-0617	CL-6	XNS-0520	S2.5
A40T-MCLNR/L12	40	27	300	50	CNMM1204	2613-5016	2613-6016					
A50T-MCLNR/L12	50	35	300	63	CNMM1204	2613-5018	2613-6018	C1604B	NL-0822	CL-12	XNS-0829	S3/S4
A32S-MCLNR/L16	32	22	250	40	CNMM1606	2613-5020	2613-6020					
A40T-MCLNR/L16	40	27	300	50	CNMM1606	2613-5022	2613-6022	C1604B	NL-0822	CL-12	XNS-0829	S3/S4
A50T-MCLNR/L16	50	35	300	63	CNMM1606	2613-5024	2613-6024					

英制

MODEL #	DIMENSIONS				INSERT SIZE	ITEM NO.		SHIM	PIN	CLAMP	CLAMP SCREW	WRENCH
	D	F	L	MIN BORE		RIGHT	LEFT					
A12R-MCLNR/L4	.75	.50	8.0	1.00	CNMG432	2613-5026	2613-6026	/	NL-0611	CL-6	XNS-0520	S2.5
A16S-MCLNR/L4	1.00	.651	10.0	1.25	CNMG432	2613-5028	2613-6028					
A20T-MCLNR/L4	1.25	.875	12.0	1.50	CNMG432	2613-5030	2613-6030	C1203B	NL-0617	CL-6	XNS-0520	S2.5
A24T-MCLNR/L4	1.50	1.062	12.0	2.00	CNMG432	2613-5032	2613-6032					
A20T-MCLNR/L5	1.25	.875	12.0	1.50	CNMG543	2613-5034	2613-6034	C1604B	NL-0822	CL-12	XNS-0829	S3/S4
A24T-MCLNR/L5	1.50	1.062	12.0	2.00	CNMG543	2613-5036	2613-6036					







# Cutoutil

Metal Carbide Inserts, Turning Tools, Indexable Milling, Carbide Drill

www.cutoutil.com

## S-MTFNR/L 90°内孔镗刀

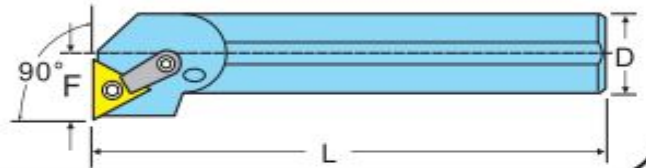
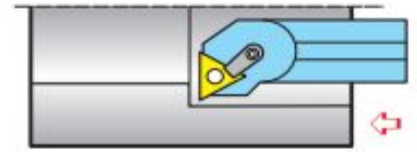

### S-MTFNR/L

型号 #	刀体几何尺寸				刀片	货号		刀垫	镀层销	压板	压板螺钉	扳手
	D	F	L	最小镗孔		左刀	右刀					
S16R-MTFNR/L16	16	11	200	20	TNMG1604	2614-0008	2614-1008	T1603B	NL-0412	CL-6	XNS-0520	S2/S2.5
S20S-MTFNR/L16	20	13	250	25	TNMG1604	2614-0010	2614-1010					
S25T-MTFNR/L16	25	17	300	32	TNMG1604	2614-0012	2614-1012					
S32U-MTFNR/L16	32	22	350	40	TNMG1604	2614-0014	2614-1014					
S40U-MTFNR/L16	40	27	350	50	TNMG1604	2614-0016	2614-1016					
S50V-MTFNR/L16	50	35	400	63	TNMG1604	2614-0018	2614-1018					

英制

MODEL #	DIMENSIONS				INSERT SIZE	ITEM NO.		SHIM	PIN	CLAMP	CLAMP SCREW	WRENCH
	D	F	L	MIN BORE		RIGHT	LEFT					
S10S-MTFNR/L3	.625	.406	8.0	.812	TNMG33	2614-3008	2614-4008	T1603B	NL-0412	CL-6	XNS-0520	S2/S2.5
S12S-MTFNR/L3	.75	.50	10.0	1.00	TNMG33	2614-3010	2614-4010					
S16T-MTFNR/L3	1.00	.651	12.0	1.25	TNMG33	2614-3012	2614-4012					
S20U-MTFNR/L3	1.25	.875	14.0	1.50	TNMG33	2614-3014	2614-4014					
S24U-MTFNR/L3	1.50	1.062	14.0	2.00	TNMG33	2614-3016	2614-4016					

### A-MTFNR/L(内冷却孔)

型号 #	刀体几何尺寸				刀片	货号		刀垫	镀层销	压板	压板螺钉	扳手
	D	F	L	最小镗孔		左刀	右刀					
A16M-MTFNR/L16	16	11	150	20	TNMM1604	2613-5001	2613-5002	T1603B	NL-0412	CL-6	XNS-0520	S2/S2.5
A20Q-MTFNR/L16	20	13	180	25	TNMM1604	2613-5003	2613-5004					
A25R-MTFNR/L16	25	17	200	32	TNMM1604	2613-5005	2613-5006					
A32S-MTFNR/L16	32	22	250	40	TNMM1604	2613-5007	2613-5008					
A40T-MTFNR/L16	40	27	300	50	TNMM1604	2613-5009	2613-5010					
A50T-MTFNR/L16	50	35	300	63	TNMM1604	2613-5011	2613-5012					

英制

MODEL #	DIMENSIONS				INSERT SIZE	ITEM NO.		SHIM	PIN	CLAMP	CLAMP SCREW	WRENCH
	D	F	L	MIN BORE		RIGHT	LEFT					
A10Q-MTFNR/L3	.625	.406	7.0	.812	TNMG332	2613-5013	2613-5014	T1603B	NL-0412	CL-6	XNS-0520	S2/S2.5
A12R-MTFNR/L3	.75	.50	8.0	1.00	TNMG332	2613-5015	2613-5016					
A16S-MTFNR/L3	1.00	.651	10.0	1.25	TNMG332	2613-5017	2613-5018					
A20T-MTFNR/L3	1.25	.875	12.0	1.50	TNMG332	2613-5019	2613-5020					
A24T-MTFNR/L3	1.50	1.062	12.0	2.00	TNMG332	2613-5021	2613-5022					





# Cutoutil

Metal Carbide Inserts, Turning Tools, Indexable Milling, Carbide Drill

www.cutoutil.com

## S-MSKNR/L 75°内孔镗刀

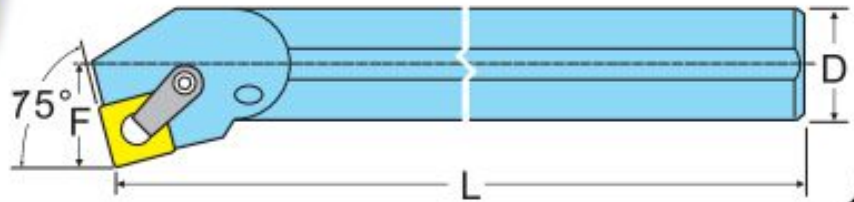
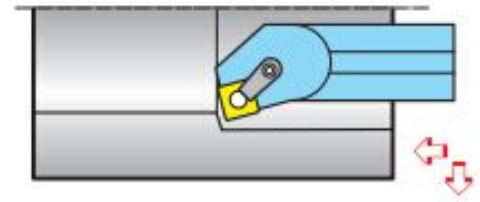

## S-MSKNR/L

型号 #	刀体几何尺寸				刀片	货号		刀垫	螺纹销	压板	压板螺钉	扳手/卡圈
	D	F	L	最小镗孔		左刀	右刀					
S25T-MSKNR/L12	25	17	300	32	SNMM1204	2616-0020	2616-1020	S1203B	NL-0611	CL-6	XNS-0520	S2.5
S32U-MSKNR/L12	32	22	350	40	SNMM1204	2616-0022	2616-1022		NL-0617			
S40U-MSKNR/L12	40	27	350	50	SNMM1204	2616-0024	2616-1024					
S50V-MSKNR/L12	50	35	400	64	SNMM1204	2616-0026	2616-1026					
S40U-MSKNR/L15	40	27	350	50	SNMM1506	2616-0028	2616-1028	S1504B	NL-0822	CL-12	XNS-0829	S3/S4
S50V-MSKNR/L15	50	35	400	63	SNMM1506	2616-0030	2616-1030					

## 英制

MODEL #	DIMENSIONS				INSERT SIZE	ITEM NO.		SHIM	SHIM PIN	CLAMP	CLAMP SCREW	WRENCH
	D	F	L	MIN BORE		RIGHT	LEFT					
S16T-MSKNR/L4	1.00	.651	12.0	1.25	SNMM432	2616-2012	2616-3012	S1203B	NL-0611	CL-6	XNS-0520	S2.5
S20U-MSKNR/L4	1.25	.875	14.0	1.50	SNMM432	2616-2014	2616-3014		NL-0617			
S24U-MSKNR/L4	1.50	1.062	14.0	2.00	SNMM432	2616-2016	2616-3016					
S20U-MSKNR/L5	1.25	.875	14.0	1.50	SNMM543	2616-2018	2616-3018	S1504B	NL-0822	CL-12	XNS-0829	S3/S4
S24U-MSKNR/L5	1.50	1.062	14.0	2.00	SNMM543	2616-2020	2616-3020					